



8



67



58



43



31



45

- 3** Presentation
- 4** Wire
- 6** Breeding boxes
- 8** Article with Jan and Loes Janssen from Janssen Farming Group
- 9** Mountings, fittings and Hogrings
- 12** Water Equipment
- 13** Mink Sheds
- 17** Manure systems
- 19** Theme day in Hering
- 20** Article with Jens Peter Larsen from Fox Farm
- 21** FarmManager
- 22** Jasopels Feeding Machines
- 23** Article with Ejgil Markussen
- 27** Spare parts for feeding machines
- 29** Jasopels MultiUnit + Jasopels BlueMotion
- 30** Jasopels Grading Table
- 31** Jasopels Length Measuring Device + Article with Jens Peter Larsen from Fox Farm
- 32** Training
- 33** Website
- 35** Article with Torben Madsen
- 36** Jasopels Drums
- 42** Jasopels Paw Cutter
New location in Poland
- 43** Article with Kenneth Dalentoft
- 44** Jasopels Slicing Machine T4 XL
- 45** Article with Loes Janssen from Janssens Farming Group
- 48** Jasopels MaxiHook T5
- 49** Jasopels Skinning Machine T4 XL + Jasopels Skinning Machine T11
- 50** Article with Henning Henriksen
- 51** Jasopels Skinning Tower + Jasopels Skinning Tower XL
- 53** Article with Hans og Claus Christensen
- 54** Jasopels Pelting Robot XXL
- 56** Article with Artur Krawczyński from Fortuna Agricultural and Breeding Farm
- 57** Jasopels Fleshing Machine T6
- 58** Article with Martin Sinkjær
- 60** Jasopels Fleshing Machine T4 XL
- 61** Jasopels Rotating Fleshing Machine 4000 XXL
- 64** Jasopels Impellers
- 66** Sharpening of Impellers
- 67** Jasopels Skin washer + Article with Kim Drejer From Drejer Mink + Article with Bo Kloster
- 68** Sawdust + Article with Niels Vesterholm from Ølholm Mink
- 69** Article with Bjarne and Michael Mikkelsen from Kær I/S
- 70** Article with Artur Andrzejewski from Bono Fur Farm
- 71** Jasopels WRAP Machine T5 Maxi Stretch
- 72** Article with Pelting Center Sydvestjysk in Varde
- 73** Jasopels Maxi Trolley
- 74** Article with Artur Andrzejewski from Bono Fur Farm
- 75** Easy Off Boards
- 76** Article with Jarosław Jasiński from Krzysztof Jasiński's Fur-bearing Animal Farm.
- 77** Jasopels Cleaning Automat T5
- 78** Article with Jan Albertsen from Tvis Pelsdyrfarm ApS
- 79** Jasopels Q-Vex Clima
- 80** Jasopels Soft Brush
- 81** Jasopels Quick Softer 4M Automatic
- 82** Compressors
- 83** Farm articles
- 85** Gloves
- 86** Machine overview and product specifications
- 89** Terms and conditions
- 90** World wide Agents
- 91** Contacts

PART OF THE TEAM



The mink industry is, despite its large geographical spread, a relatively small one – and we probably know each other already. In this way we are almost a family, and if not – definitely very close to each other. We are so close that your everyday work on the farm affects us, who develop, manufacture and service products that make everyday life easier for you as a mink farmer. We call it unity.

Challenged by disease

Unity is indeed necessary to make the industry exciting and makes us want to come to work every morning. The fact that we are closely connected was visible in the past year, when some farms were hit by disease. This affected us deeply at Jasopels, and we have worked with the industry to find its causes and solutions to effectively stop its spreading.

New factory in Poland

At Jasopels we have a strong belief in the future and that we must continue to develop both our products and business. Therefore, in 2016 we will inaugurate our new plant in Oborniki in Poland. There we have modern new premises. With modern facilities and production equipment we can raise our quality and efficiency. This gives our employees more job satisfaction and quality products to our customers. You may see our new factory on page 42.

Tested in real life

Unity, cooperation and direct contact are crucial in developing a company, and let us create the machines and solutions that drive the industry forward. We generally receive praise from customers, but the highest praise should be directed the other way – to you, our customers, that every day test our products in real life and tell us what we can do better.

Enjoy this new 2016 catalogue from Jasopels!

Poul A. Bach



CrapalPremium® Sold only by Jasopels.

CrapalPremium® is ArcelorMittal WireSolutions' patented zinc+aluminium+magnesium alloy.

This extra anti-rust alloy is especially designed for users who have high expectations regarding the product's lifespan. This alloy is guaranteed to have a lifespan that is 8 times longer than of similar heavily galvanized products exposed to the same conditions.

CrapalPremium® is an anti-rust alloy that consists of 95% zinc and 5% aluminium as well as a controlled content of magnesium. CrapalPremium® can also be delivered in plasticized coils and panels.

Based on this unique combination of elements Jasopels A/S produces a cage called MAXI PREMIUM. MAXI because we use 2 bottom panels made of 2,45mm thick wire, turned "against each other" so that bottom-, rear- and top wire are 2,45mm. PREMIUM as it is obviously the abovementioned strong alloy which at the same time makes the wire smoother and thus easier to keep clean, unlike standard Aluzinc cages. The cage is reversible, once the shelf is placed correctly. This type of cage finally eliminates the problem of corrosion which always occurs when a cage has stainless steel bottom but AZ partition walls and rear panels.



JASOPELS – WHEN TOP QUALITY MUST BE AT THE RIGHT PRICE!

Our reversible cages made of pure PREMIUM wire are an advantageous purchase nowadays as the high contents of zinc and magnesium ensures a significantly longer service life compared to other well-known alloys.

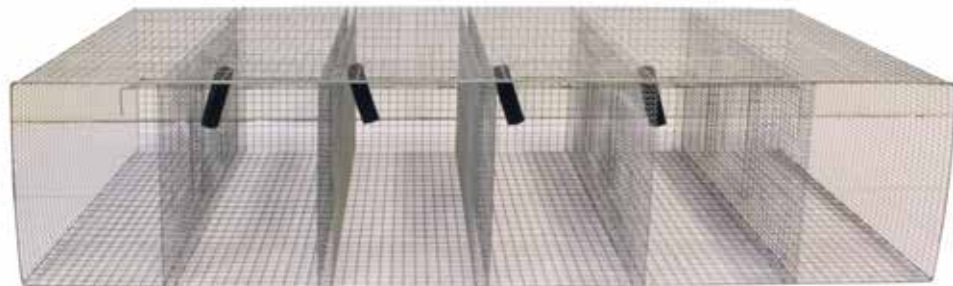

ASSEMBLED CAGES

Item no.	Product description	Price
20100197	Top part of double cage 3D with blue PVC partition wall premium, incl. front door	*
20100019	Top part 14" 3 animals 14"x77"x18" incl. front door and wire	*
20100016	Top part 6 compartments 27" Incl. front door, pure PREMIUM	*
20300018	6/90 cm MAXI top wire Stainless bottom, with bent 9" 2,45 mm	*
20300019	6/90 cm ¾"x1" Stainless bottom, with bent 9" 2,45 mm and stainless feeding wire	*
20100023	6/90 cm MAXI With 2 x MAXI PREMIUM, Ø 2,45 mm	*

All cages are also available as completely STAINLESS cages

UNASSAMBLER CAGES

Item no.	Product description	Price
20100198	Top part of double cage 3D with blue PVC partition wall premium, incl. front door	*
20100006	Top part 14" 3 animals 14"x77"x18" incl. front door and wire	*
20100002	Top part 6 compartments 27" Incl. front door, pure PREMIUM	*
20300004	6/90 cm MAXI top wire Stainless bottom, with bent 9" 2,45 mm	*
20300009	6/90 cm ¾"x1" Stainless bottom, with bent 9" 2,45 mm and stainless feeding wire	*
20200006	6/90 cm ¾"x1" Stainless 2 x bottom, with bent, completely stainless	*
20100010	6/90 cm MAXI With 2 x MAXI PREMIUM 2,45 mm	*

CRAPALPREMIUM®



Our 7 – compartment STAINLESS cage with a thick 2,45 mm bottom wire and 2,00 mm top- and rear wire and blue PVC partitions walls is an excellent alternative to the standard stainless cage as you get 1/6 extra compartment on the same space for a lower price.

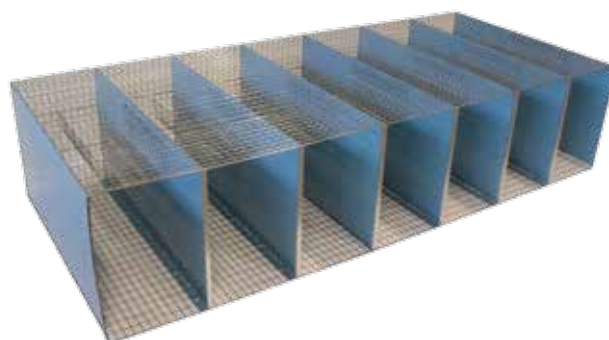

WIRE PANELS

Item no.	Product description	Price
20100073	Feeding wire 1"x1" x 8"x77"	*
20100074	Feeding wire 1"x1" x 8"x77"	*
20100078	Feeding wire 1"x1" x 9"x77"	*
20200058	Bottom panel, stainless 23x1,5" + 1x2" Ø2,45	*
20200059	Bottom panel, stainless 9x1"+17"x1,5+1x2" Ø2,45	*
20100088	Bottom wire, combi 1" x 1" x 1½" x 36" - 91 c	*
20100042	Partition wall 18"x 36" 45 cm Crapal unass	*
20100082	Back wire 1" x 1" x 18" x 77" Ø2,00	*
20100090	Bottom wire Maxi PREMIUM 45" x 77, bent	*
	Feeding wire PREMIUM can be delivered also in 2,45 mm	



PUPPY NET CRAPALPREMIUM®

Item no.	Product description	Price
20100065	1 Puppy net, 90 cm, plastic without frame 11,5"x36" = 29 cm x 91 cm	*
20100066	2 Puppy net, 90 cm. plastic with frame 11,5"x36" = 29 cm x 91 cm	*
20300024	Frame for puppy net, 90 cm	*

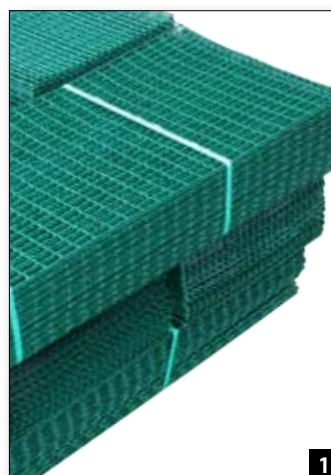

1



2



It is a priority for us to keep developing products that are durable and highly functional, which is why we are able to offer you the most attractive breeding box on the market. Our breeding boxes are made of 11 layers of hard-pressed birch plywood.

A unique groove in the rear panel for the locking spring, which ensures a pleasant and easy open/close function. Thanks to the tapered grooves in the panels, the countersunk holes have no annoying edges. All mountings are of stainless steel, so the quality is perfect.

We have a very strong standard program regarding deliveries of many types of breeding boxes at attractive prices.

- All holes are pre-drilled to ensure correct mounting of fittings
- All partition walls are pre-drilled to ensure correct assembly of boxes
- Unique grooves in the rear panels eliminate the need to install locks
- 120 mm hole in the front panel.

PATENTED



"NO MORE SORE FINGERS"

Newly developed closing mechanisms for nesting boxes.

Jasopels team tries every day to find new solutions to make everyday work easy for you and your employees.

Here is one of the new products that is certainly a pleasure to have on your farm.

It can be used in virtually all models, also when you want to replace your old type lids.

Order a sample from your sales representative.

DOORS

Item no.	Product description	Price
20100152	Locking spring, ass, 9"x12", 1"x1"	*
20100144	Bottom doors 12"x11", 1/2"x1"	*
20100138	Cage door 12"x11", combi, with hinges	*
20100137	Cage door 12"x11", 1/2"x1" with hinges	*
20100141	Cage door 12"x12", combi with hinges	*

Doors are also available in STAINLESS wire

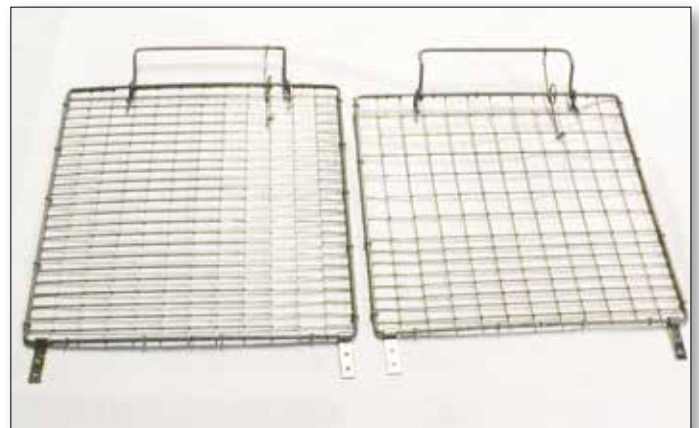

BREEDING BOXES

Item no.	Product description	Price
21200014	Breeding box, 6 compartments, birch plywood, incl. nest Nesting box - without cover	*
21200009	Breeding box, 6 compartments, birch type, ass. 12"x9" Adjust. height - without cover	*
21100008	Breeding box, 6 compartments, Dutch type, ass 12"x9" Adjust. height - without cover	*
21100011	Breeding box, 6 compartments, Dutch type, ass., incl. nest ass., plastic, with cover, without shutter 12"x9"	*



BREEDING BOXES XL-BOX

Item no.	Product description	Price
21200011	Breeding box XL, 6 compartments, birch, incl. nest 12"x11" or 12" x 10" incl. nest, without shutter. Note: without cover	*
21200010	Breeding box XL, 6 compartments, birch, ass., 11x12" - Special for double cage with adjust. height. Note: without cover	*



NESTS



Item no.	Product description	Price
20100160	Nest, plastic, 9"x12", without lid	*
20100163	Nest 9"x12", with stainless lid 1"x3/4"	*
20100166	Nest, plastic, 10"x12" with Crapal lid	*
20100168	Nest, plastic, 11"x12" with lid	*
20100104	Plastic nest bottom, 9"x12", 1/2"x1"	*
20100154	Locking spring, 9" x 12", 1"x1"	*



CAGES AND BREEDING BOXES

“All cages and breeding boxes look similar when you buy them. What’s important is how they look after years of use. The products manufactured by Jasopels are made from quality materials, and are easy to keep clean. Quality is always worth it.” explain Jan and Loes Janssen from Janssen Farming Group.

You run a family mink farm near Gorzów. How did it all begin?

Jan: In my case it’s a really long story. More than 35 years ago I tried raising different kinds of animals, including pigs and cows. It was mink, however, that triggered my interest. My first farm consisted of just 100 animals. It was practically a hobby. Eighteen years ago I took up mink breeding seriously here in Poland, because it’s such a beautiful country with many opportunities.

Loes: It’s true that Poland is beautiful and I have always been fascinated by its nature, but I have to admit that I didn’t plan to work on a mink farm when I was younger. I attended an economics school, but I was always attracted to animals. As a child I helped my father on the farm when it was needed. In 2009 I went to Canada for a six-month course of studies. That was a real eye opener for me, because I learned that there was a lot more to explore outside the Netherlands. So the day after I graduated I practically moved to Poland together with my horses. And now, I’ve been here for nearly six years and it was the best decision I ever made.

What makes Jasopels cages different from other companies’ products?

Jan: All cages look very similar when you buy them. What’s important is how they look after a few, or even after a few dozen years. We’ve just built new sheds for breeding, and for us it’s very important that everything inside is of the best quality, built to last for years.

Loes: The first that comes to my mind is that it’s very easy to open and close the cages. It’s also no problem to clean them thoroughly. Incidentally, we’ve also installed an automatic watering system and a manure handling system from Jasopels.

Was it a large investment?

Jan: Oh yeah, very costly, but worth the price we paid. Whenever we had questions it was enough to call and we were able to work everything out. We always managed to find a solution.

Loes: Aftersales service is very important. Previously, when we bought cages from another manufacturer, the delivery person simply unloaded the goods and drove away. When something broke down, there was no one to help us. Lack of contact, in other words lack of a professional approach on the part of the manufacturer, is a serious problem. With Jasopels, it’s completely different.

How long have you been using Jasopels machinery?

Jan: For a long time. One of the first machines I bought when I began my adventure with mink was from Jasopels. I’ve always been satisfied with their products, that’s why now, during our modernisation of the farm, we’re buying more from them.



MOUNTINGS, FITTINGS AND HOGRINGS

Item no.	Product description	Price
21100028	1 Angle hinge 65 x 65 x 11 mm	0,30
21100027	2 Angle hinge 110 mm x 20 mm 2,04 mm	0,35
21100018	3 Locking plate for breeding box	0,20
21100020	4 Metal whirl	0,25
21100026	5 Cage hook for breeding box, stainless	0,30
12300084	6 Band for breeding box, 14 cm x 50 m.	20,30
12300088	7 Manual band rewriter	*
22100155	8 Torx screws for front doors 3,5 x 15, 1.000 pcs.	26,40
21100033	9 Shutter/bulkhead rail, stainless	0,30
21100034	10 Shutter/bulkhead, galvanized, for 12 cm hole 140 mm. wide	1,75
21100036	11 Shutter, "fork model"	12,85
21100039	12 Alu. plate, hole in the middle	1,95
21100038	13 Alu. plate, hole on the side	1,95
21100037	14 Spring for cage door, stainless	0,25
21100047	15 Cage hook, 12,8 cm	0,60
21100054	16 Cage hook, 95 cm	0,85
22100039	17 Cage card holder, Morsø, plastic, with screw	0,20
22100037	18 Cage card holder, stainless, short, without screw	0,25
22100038	19 Cage card holder, stainless, long, without screw	0,30
22100040	20 Cage card holder, Morsø, plastic, double, multi	0,25
22100041	21 Cage card holder, stainless, double, BK model	3,75
20100027	22 Loose hogrings 1/2" aluminium/zinc	10,15
20100026	Loose hogrings 3/8" Crapal alu/zinc	10,15
20200016	Loose hogrings 1/2" stainless, approx. 1100 pcs./kg	18,55
20200015	Loose hogrings 3/8" stainless, approx. 1100 pcs./kg	16,25
12200094	23 C-rings 3/8" aluminium/zinc magazine 15.680 pcs.	100,00
20200022	C-rings 3/8" stainless, magazine 15.680 pcs.	190,00
20100034	24 A-16 rings alu magazine 1.000 pcs.	12,00
20200024	A-16 rings stainless magazine	37,16



PLIERS/TONGS



Item no.	Product description	Price
12600013	1 Pliers/tong, Swedish	45,00
12600014	2 Pliers/tong, with magazine, Ottensten	62,85
12600009	3 Jaspels C-ring pistol	675,00
12600018	4 Cutter, pneumatic, MR-20	330,00
12600021	Cutter, pneumatic, MR-30 A, Large	370,00
12600019	5 Jaws for MR-20, P6	105,30
12600022	Jaws for MR-30 A P8P, Large	82,50
12600016	6 Wire cutter, electric, Bosch	470,00

TOYS/SHELVES

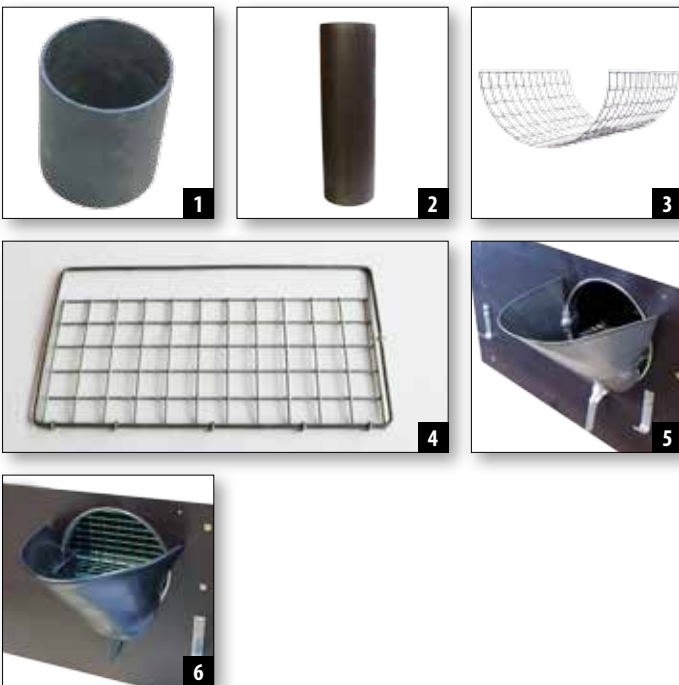

Item no.	Product description	Price
12600080	1 Tube GVA R120 x 155 x 5 mm	0,80
12600082	2 Tube, Ø40 mm GM	0,40
20100124	3 Shelf for cage 12 x 14" rolled	1,60
20100096	4 Shelf for cage 5"x11" wire/frame	6,00
12600069	5 Uniq screen, 16 mm	3,30
12600072	6 Screen module, NF, plastic, black	1,60

FLIGHT TRANSPORT BOXES



Item no.	Product description	Price
12600055	Flight box, 5 compartments, female	*
12600056	Flight box, 4 compartments, male	*
12600057	Wire + plastic, 6 compartments For females (compartment = 5"x5")	*
12600093	Wire + plastic, 5 compartments For males (compartment = 5"x6")	*
12600094	Separating paper for flight boxes 75 cm x 115 cm	*



CRAPAL[®] PREMIUM

Zink + Aluminium + Magnesium alloy
for active and long term corrosion protection

- ✓ Guaranteed quality
- ✓ Guaranteed environmental friendliness
- ✓ Guaranteed economical advantages
- ✓ Guaranteed prolonged lifespan

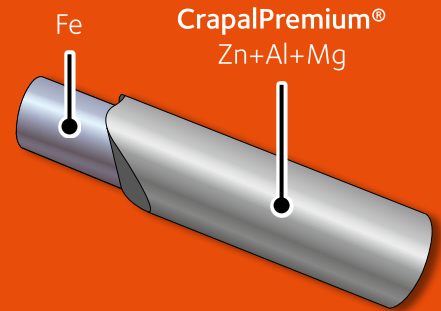

Salt spray test according to EN 50021 SS/ISO 9227

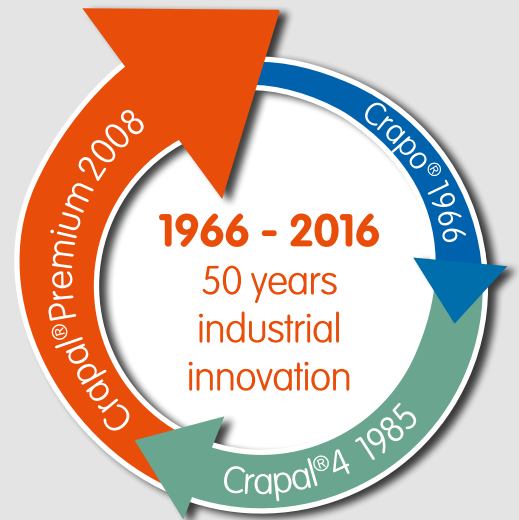
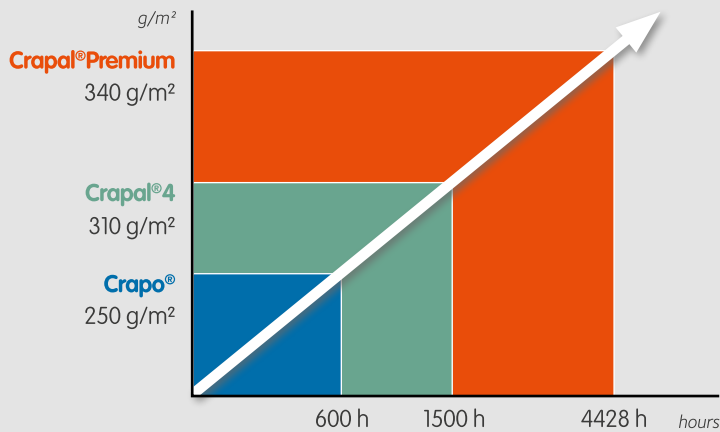

Jasopels A/S Fabriksvej 19 DK-7441 Bording
Phone +45 98 42 05 66 -www.jasopels.com



ArcelorMittal

birgit.lang@arcelormittal.com
www.arcelormittal.com/wiresolutions



1966



1985



2007



2008



2013

WATER EQUIPMENT

Item no.	Product description	Price
12200028	1 Drinking valve, biting, Gjøl, green	0,75
12200030	2 Drinking valve, biting, thermo, Gjøl, green	0,95
12200023	3 Valve, biting, stainless, white, Columbus	0,70
12200024	4 Valve, biting, stainless, black, Columbus	0,80
12200020	5 Valve, biting, ØKO, incl. steel holder, Morsø	0,80
12200015	6 Gasket for valve	0,08
12200012	7 Valve holder, single	0,11
12200013	Retaining spring til valve, Double	0,11
12200014	Retaining spring til Forelco Thermoslange	0,25
12200021	8 Metal holder for Morsø valves	0,25
12200034	9 Metal holder for drinking valve, stainless	0,25
12200041	10 Connector, black, 3/4", with inner gasket	2,05
12200038	11 Connector, RG, 3/4", for PEL hose	5,55
12200037	12 Connector, 3/4", for PEL hose	1,55
12200040	13 Hose connection without screw cap, 3/4", for pipe	3,40
12200039	14 Hose connection with screw cap, 3/4", for pipe	3,40
12200056	15 Angle, RG, 3/4", for PEL hose	7,10
12200057	16 Angle 3/4" with screw cap	3,40
12200058	17 Angle 3/4" without screw cap	3,40
12200055	18 Angle, 3/4", for PEL hose	1,50
12200054	19 T-pipe, 3/4", for PEL hose	1,80
12200053	20 T-piece, RG, 3/4", for PEL hose	12,85
12200059	21 Screw cap, RG, foe PEL hose	3,90
12200062	22 Plastic tap, 3/4", for PEL hose	13,40
12200074	23 Reducing valve, RG, without manometer	89,20
12200075	24 Manometer for reducing valve	12,85
12200076	25 Repair kit for RG reducing valve	53,40
12200086	26 Draining	0,60
12200087	27 Draining for drinking valve, Morsø	0,60
12200088	28 Drinking cup, Berima, double	0,90
12200044	29 Thermopipe, Gjøl, 6 rooms, 206 cm, incl. green valves	15,55
12200035	30 PEL hose, 3/4", 100 m	85,00
12200065	31 Loop, complete	13,10
50500071	32 Clamp 3/4, 22-32	2,70



MINK SHEDS

A mink shed is a part of a mink breeder's production facilities. Therefore, Jasopels' main premise says:

The PRODUCTION should take place in the sheds.

Effectively and at low cost. With equipment which provides optimal conditions for animals. Because good animal welfare results in better skins and thus, higher income.

All innovation at Jasopels is focused on the quality of the final product.

To improve the efficiency and optimize work at a mink farm, regardless of whether it comes to sheds and equipment, or machines and farm articles.

That is why feeding passages in Jasopels mink sheds are 140 cm wide to support more effective operation, 70 cm wide ridges for providing more light and at the same time 70x70 mm purlins to resist huge amounts of snow and heavy storms.



12 ROWS MINK SHEDS



The wood is planed and of the best quality. All the rafters for 2-, 4- and 6-row sheds are supplied in bundles, and may be used as DIY construction. **1**
 All rafters come with brackets for nest boxes, factory fitted on the rafter. **2**
 All rafters are calculated according to Eurocode EC-DK. All rafters are delivered with the dimensions of AT LEAST 45 mm x 95 mm – for both the rafter and roofing. **3**

In addition, Jasopels can at any time deliver rafters to size, in case sheds must be lengthened or you need specially designed rafters. We do not take additional fees for measuring the rafters.

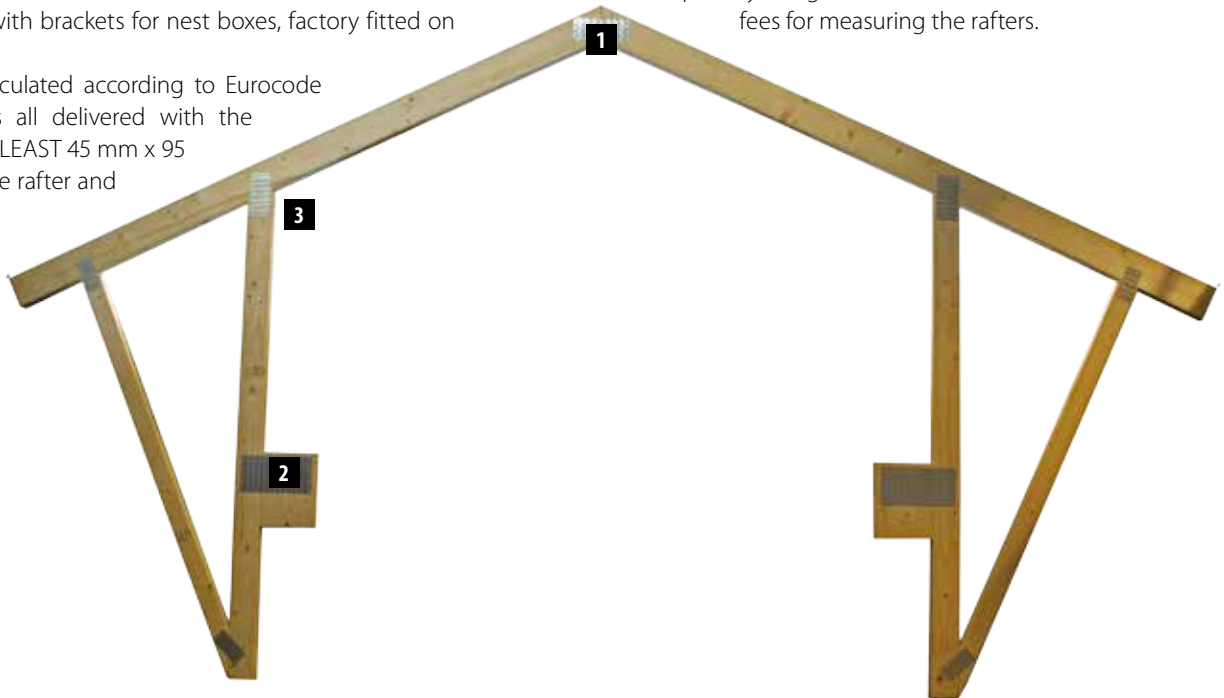

ROOFING SHEETS

Roof sheets of 2-row sheds can be delivered in FULL length.



FRONT AND WALL PANELLING



Front and wall panelling is provided with Plastisol-treated trapezoidal plates.

ROOF GUTTERS



The gutters supplied are by default STEEL ROOF GUTTERS from LINDAB.

HALLS WITH FIRE VENTILATION



Closed sheds are equipped with with bird-proof smoke ventilation.

ROOFLIGHTS



ROOFLIGHTS – rooflights are as standard available in 1,2 mm thick sheets but our POLYCARBONATE sheets can be highly recommended as they are much more resistant to UV radiation, which has increased in intensity over last several years.

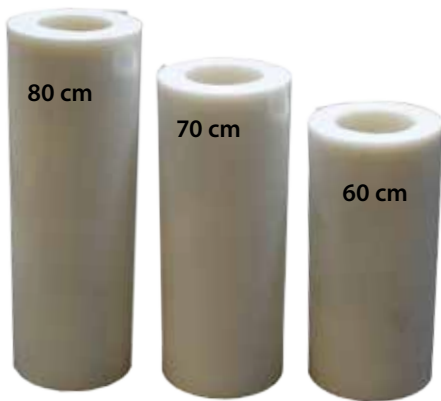

The ridges delivered are in the best available quality.

They are 1.5 mm thick, UV-resistant and extra stiff, which makes the installation easy and ensures that the curved shape is maintained after installation.

Item no.	Product description	Price
22100129	Ridge 50 cm x 25 m, white, 29 rolls/pallet	*
22100130	Ridge 60 cm x 25 m, white, 29 rolls/pallet	*
22100131	Ridge 70 cm x 25 m, white, 29 rolls/pallet	*
22100133	Ridge 80 cm x 25 m, white, 29 rolls/pallet	*
22100127	Ridge 100 cm, white, max. 25 m/rolls	*

STEEL CONSOLES



Item no.	Product description	Price
21100061	1 Steel console	*
22100008	2 Steel console, model Uniq	*

Jasopels produces galvanized steel consoles for cages, breeding boxes and manure pipes. They can be used in sheds with steel rafters etc.

The consoles can be found in various versions: with “feet” – for mounting on concrete floors and other level surfaces or with longer “legs” for imbedding. The consoles are made of 30 mm rectangular pipes with welded-on galvanized brackets for manure pipes and plates for mounting of mink data cards.



MANURE SYSTEMS

Jasopels does not compromise...

Jasopels offer the most flexible manure system on the market – tailored to your farm and your needs. We are ready to deliver back flush systems with dry-mounted pumps.

We do not compromise when it comes to our common goal – the environment. All materials are therefore approved for this purpose and the installation is, of course, performed by specially trained employees. Jasopels offers all the commonly known manure systems, both Farmcat and wire drive solutions.

JASOPELS FARMCAT

Efficient manure removal with the Jasopels FarmCat.

The wireless Jasopels FarmCat handles automatic manure removal of the mink shed accurately and efficiently with minimal maintenance necessary.

The new FarmCat is fitted with a more powerful motor, improved forward drive, more powerful battery with triple battery life, automatic charging between operation intervals, and new, future-proofed control system that can be adjusted individually in relation to requirements on the individual farm.

Item no.	Product description	Price
23100111	Jasopels FarmCat, double, right Running over fallout middle	*
23100112	Jasopels FarmCat, double, left Running over fallout middle	*
23100115	Jasopels FarmCat Type 2, right/single for > 50 spans	*
23100116	Jasopels FarmCat Type 2, left/single for > 50 spans	*

PUMPS

Item no.	Product description	Price
23100103	Pump 6,5 hp, dry mounting	*
23100101	Pump, 2 hp, back flush, complete	*
23100099	Control cabinet with interval start	*
23100095	Tank overflow 160 mm, galvanized	*
23100104	Dry well 1000 x 2000 mm	*



- **Minimal maintenance**
- **Made of stainless steel**
- **Double wheel drive**
- **Single model – for fallout in the rear**
- **Double model – for fallout in the middle**

GUTTERS AND FITTINGS

Item no.	Product description	Price
23100026	Manure pipe, Gjøl, grey, 350 mm of 6 m.	*
23100049	Drain, Gjøl, grey/black, excl. gutter	*
23100028	End, Gjøl, grey, 350 mm	*
23100029	Suspension for Gjøl drain, 680 mm, incl. bolt	*
23100033	Hanger for Gjøl end panel	*
23100034	Suspension strap, flat steel 20x3 mm	*
23100052	Manure scraper, manual for Gjøl	*
23100018	Set og gutters 6 pcs, screws + silicone	*



JASOP

Fodercentral Service A/S

We entered into a cooperation agreement for the sale and servicing of machinery for the production of mink food with Scansteel Foodtech.

After many years of cooperating, CFS/GEA has decided to cease the production of mixing machines and straw cutters.

Of course we will continue servicing all CFS/GEA machines and offering spare parts for the machinery in future.

We are negotiating with Petsmo about mink food containers, pumps, etc. and with Poul Tarp weighing systems. Moreover, we offer a broad range of second hand-machines and tank vehicles.

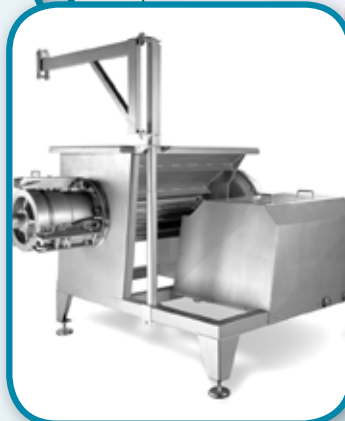
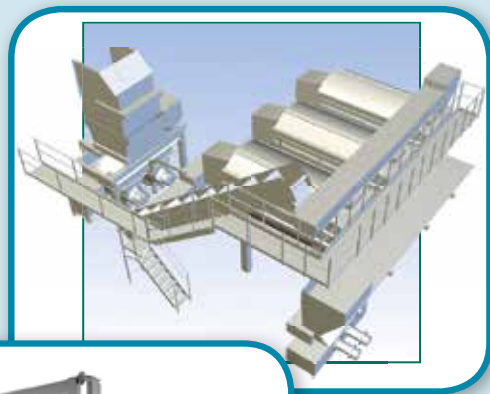

JASOP

Fodercentral Service A/S

Jasop Fodercentral Service A/S | Knivholtvej 7 | DK-9900 Frederikshavn

Tlf. + 45 98 43 05 66 | Fax + 45 98 43 59 77 | E-mail: info@jasop.dk | www.jasop.dk

THEME DAY IN HERNING

Meet us in Herning on the 26th of August 2016. Here we will show some of our well-known pelting machines in operation.

Now you got the possibility to see how quick and easy our succesful Easy Off board is to use in the daily operation. Our sales- and service-team will be ready for any conversation.





HEALTHIER FARM AND SAVINGS IN TIME WITH FARM MANAGER

With Jasopels Farm Manager it is possible for Fox Farm to steer clear of overfeeding, get proper amount of feed and bring mink to their optimal size

A year ago Jens Peter Larsen from Fox Farm had a Farm Manager system installed on the feeding machine. His goal was to optimize feeding on the farm and maybe get a little more income because of better management.

– Farm Manager is ingenious in the period of growth. Health control became easier. We have an impression that better management of feeding has brought effect and we have gained some time, re-counts Jens Peter Larsen.

They save approx. 1,5 hours a day.

– In the past it felt as if I was sitting on the feeding machine all day long. Not any more, states Jens Peter Larsen, who estimates that now feeding takes between 2,5 and 3 hours.

No more overfeeding puppies

The new system has paid off especially during the puppy season.

– I think it is way easier to manage the feeding during the puppy season. We have generally managed to avoid overfeeding the puppies in the past season, says Jens Peter Larsen.

When a female has a puppy, the new data is introduced into the Farm Manager system.

– The system draws a curve with the amount of daily feed increased by 2-3 %, and the feeding continues until the puppies are taken away from the female. It is really smart, states Jens Peter Larsen.

Unlike other systems, Farm Manager is integrated with the feeding machine.

– It is obviously a huge advantage that the whole system is close at hand when you are sitting on the machine and you can e.g. click on an icon with an animal which has eaten everything, says Jens Peter Larsen.

Payback of investment within 1 year

Installation of the system has gone smoothly providing Jens Peter Larsen with more freedom.

– Having Farm Manager I can easily ask an employee to feed because I am the one who decides about the amount of feed and not the employee's estimations, he says.

The system has a number of statistical functions; you can e.g. print out a list of dead animals. However, one of its most important functions is the one which enables you to order feed for the next dam based on the exact calculation of the predicted consumption.

– Now when I have Farm Manager I have an ongoing access to the feed consumption data and I know exactly how much feed will be used the following day. It's a really smart system, says Jens Peter Larsen.

Overall, he has no doubt that the system has so many advantages that the purchase paid for itself very quickly.

– The payback time in case of Farm Manager is only one year. We have managed to reach bigger sizes in case of many skins and additionally, it has lots of other advantages.

Last but not least, everyone at Fox Farm is quite satisfied with the support they receive in relation to Farm Manager.

– Jasopels should be praised for putting all the necessary time into introducing us to the system as well as for the follow-up, emphasizes Jens Peter Larsen.



FarmManager

Precision Overview Control Efficiency

MAYBE THE WORLD'S BEST FEEDING SYSTEM

Jasopels has hit the bull's eye with FarmManager, a feeding system capable of much more than feeding the animals individually and quickly.

Many mink farmers in Denmark as well as abroad today use Jasopels FarmManager. We have thereby received a lot of feedback, which has meant that our feeding system is now at such a high level that it can meet the demands of all farms, regardless of size.

FarmManager can today be found on farms of 1,000 females up to the largest of 50.000 females.

Call us and book an appointment for a demonstration.

Item no.	Product description	Price
40200039	FarmManager	5,400.00
40200060	Joystick for FarmManager	*
40200067	FarmManager Center PC, incl. antenna	*
40200036	Medication dosage	*

*The price is without mounting / can be mounted on any brand

- *The system automatically generates lists of sick animals.*
- *Creates records of medicine, defects on the farm, and dead animals*
- *A stable system that can withstand being knocked about, frost, and water*
- *Fast and slow feeding in the same row with no pressing of buttons necessary*
- *Quick and easy adjustment of the amount of feed for each cage*
- *Program available in several languages*
- *Fully automatic backup and multiple units that communicate and share data*
- *From the feeding machine, birth rate curves, medical records, death records, kit number, feeding statistics, and growth development can be set up without having to connect other equipment*



Jasopels Feeding machines to suit your needs

At Jasopels we have feeding machines that adapt to their tasks and your needs. All machines are easy to clean and maintain on a daily basis and they are designed to be easy to service. In addition, you may also choose from our wide range of additional equipment for individual machines.



ITEM NO. 40100004
Jasopels Feeding Machine 700 with mixer, water tank and 700 l. feed bin

A LOT OF POSSIBILITIES FOR BUYING EXTRA EQUIPMENT!



Price EUR

24.315,00

JASOPELS FEEDING MACHINE 700

Feeding Machine 700

Jasopels Feeding Machine 700 is the right machine on a farm where there is a need for high maneuverability in a compact solution of a machine with a mixer. The machine is very easy to use, even in small

spaces. By tipping the seat and the bonnet it is easy to service. Feeding tank may be effortlessly tilted forward and allows easy access for daily cleaning and service. Jasopels Feeding Machine 700 can hold 700 liters of feed and is equipped with a 26 BHP Kubota 1105 3-cylinder engine.

Specifications

4-way adjustable seat
Servo-steering, small turning radius, easy to maneuver
Turning radius 230 cm
Tiltable feed tank
Mixer.
Water dosage
Lawn pattern on wheels

Technical data

Engine	26 BHP KUBOTA 1105. 3 cyl. water-cooled diesel
Transmisson	Fully hydraulic, 40 l. tank with oil cooler
Diesel tank	40 l.
Feeding Pump	Steplessly adjustable XL gear wheel pump
Feed tank	Stainless steel, 700 l, with mixer
Water tank	Stainless steel, 50 l.
Measurements	L: 255 cm H: 147 cm W: 87 cm Seat height 152-160 cm, sitting height 109-116 cm, Tank height 147 cm

LESS TIME WASTE AND MORE ENERGY

With a new Jasopels Feeding Machine 950 Ejgil Markussen gained greater capacity, better ergonomy and more power to work.

Last autumn Ejgil Markussen bought a new Jasopels feeding machine 950 with mixer and portioning system. It was an investment which brought many benefits.

– I have 2.550 females on the farm and thanks to the mixer and big capacity of the feeding machine I can fill up two times fewer when there is time pressure. Also, 4 wheel drive means much more power, he says.

Although the new feeding machine is bigger in every aspect, the changeover has gone smoothly.

– I am a bit surprised that it is so easy to manoeuvre with it, especially in a closed shed with little space at the ends of the rows. At the same time, it is easy to keep it clean, says Ejgil Markussen.

Reverse function

A new function of the feeding machine allows the pump to move backwards, when the machine approaches the end of the row during the standard portioning.

– The feeding machine does not leave a portion feed clump in the bucket or on the ground, and that is a very useful function. We have tried out another feeding machine in which you have to emp-

ty the bucket constantly. So this one is the right solution, believes Ejgil Markussen.

As the pump moves backwards, the pressure in the hose drops and therefore there is no waste.

– Another addition is a new and smaller sprout. It makes it easier to place a small quantity of feed and to dose it precisely. It is important especially in case of puppies, as now you don't have to scrape the remains off the net any more, says Ejgil Markussen.

In his opinion, accurate dosing makes the flushing process easier.

Ergonomic armrest takes the load off your back

Ejgil Markussen and his assistant feed twice a day, except the periods of growth, when the mink are fed 4 times a day. An ergonomic armrest turned out to be very handy.

– Generally, Jasopels Feeding Machine 950 is quite comfortable to sit in. No matter if it is an even surface or a concrete floor, it drives smoothly, says Ejgil Markussen.

Earlier, he used to suffer from a pain in his arm because of non-ergonomic position while feeding.

– Clearly I can sense a relief in my arm compared to before, when I had to sit and hold the hose all the time. I always had pain in my arm when I was using other feeding machines, but this one not so stiff, it is easy to drive it and the armrest is very helpful. It really makes a difference, concludes Ejgil Markussen.



Jasopels FEEDING MACHINE 950

Jasopels Feeding Machine 950 can hold 950 liters of feed and is our smallest articulated feeding machine. The machine is equipped with a 26 BHP Kubota 1105 3-cylinder engine, which makes its nose slightly shorter and thus more maneuverable. This makes the machine able to get everywhere around the farm. In addition, the ma-

chine is equipped with 4-wheel drive. The tank is equipped with a mixer and may be tilted to the side, and therefore it is incredibly easy to clean. The feeding pump is installed in the tank and is designed to be extremely user-friendly. At the same time the machine has an effective cooling system used in larger machines. Overall, the advantage of this feeding machine is that it has a proven design in all its parts and therefore it is simple to operate and service.



**A LOT OF
POSSIBILITIES FOR
BUYING EXTRA
EQUIPMENT!**

ITEM NO. 4010007

Jasopels Feeding Machine 950 articulated, with mixer, water tank and 950 l. feed bin.

Price EUR

27.015,00

Feed bin side tilt



**Centralized lubrication system
ITEM NO. 50100161**



Additionally paid accessory

**Centralized lubrication system
ITEM NO. 50100161**



Additionally paid accessory

Specifications

- Turning radius 165 cm
- 4 WD Lawn Pattern on all 4 wheels
- 4-way adjustable seat
- Water dosage
- Maintenance friendly and movable feed tank with quick coupling to the feed hose
- Mixer.

Technical data

- Engine** 26 BHP Kubota V1105 3-cyl. water-cooled diesel
- Transmission** Fully hydraulic, 40 l. tank with oil cooler
- Steering** Servo
- Diesel tank** 40 l.
- Feeding pump** Steplessly adjustable XL gear wheel pump
- Feed tank** Stainless steel, 950 l.
- Water tank** Stainless steel, 50 l.
- Measurements** L: 325 cm. H: 155 cm. W: 92 cm.
Seat height 150-158 cm, sitting height 107-115 cm
Tank height 155 cm

JASOPELS FEEDING MACHINE 1500

Jasopels Feeding Machine 1500 - 1320 litres/1520 litres

Jasopels Feed Machine 1500 is our bestselling feeding machine, which is available in two tank sizes where only the height and thus the feed capacity is different. If you want comfort during its operation, this machine is an obvious choice, with air suspension seat and a hydraulic foot pedal, which gives a very dynamic but smooth driv-

ing. Model 1500 has, just like model 2000, a reinforced driveline around the mixer with a duplex chain and sprockets as well as stronger axle and bearings. This model is equipped with the well-known 36 BHP Kubota V1505 4-cylinder engine, which provides a quick start and good acceleration.

Jasopels 1500 feeding machine is the right choice if you want comfort during a long working day on the machine.



**A LOT OF
POSSIBILITIES FOR
BUYING EXTRA
EQUIPMENT!**

ITEM NO. 40100010

Jasopels Feeding Machine 1500 articulated with mixer, water tank and **1320 l** feed bin.

Price EUR

31.075,00

ITEM NO. 40100012

Jasopels Feeding Machine 1500 articulated with mixer, water tank and **1520 l** feed bin.

Price EUR

32.420,00

Feed bin side tilt



Feed "cutter"



36 BHP Kubota V1505 Engine



Additionally paid accessory

Specifications
Turning radius 280 cm
4WD, traction tires on all 4 wheels
4-way adjustable, air-cushioned seat
New Kubota 1505 low-emission engine
Oil cooler
Improved mixer
Water dosage
Maintenance-friendly feed tank (tiltable to the side) with a quick-action coupling on the feeding hose between tractor and trailer

Technical data	
Engine	36 BHP Kubota 1505, 4 cyl. water cooled diesel.
Transmission	Fully hydraulic, 55 l. oil tank with oil cooler
Diesel tank	55 l.
Feeding Pump	Steplessly adjustable XL gear wheel pump
Feed tank	1320 l. or 1520 l. stainless steel feed tank with mixer
Water tank	Stainless steel, 50 l.
Measurements	1320 l: L: 380 cm H.: 155 cm W: 92 cm
	Seat height 152-160 cm, Sitting height 109-117 cm, Tank height 169 cm
	1520 l: L: 380 cm H.: 169 cm B: 92 cm
	Seat height 152-160 cm, sitting height 109-117 cm, Tank height 155 cm

Jasopels FEEDING MACHINE 2000

Jasopels Feeding machine 2000 is ideal for a modern farm in need of a large feed capacity and economic performance. This is a big and powerful machine with a tiltable boogie which makes it very stable and which will make the drive on uneven surfaces pleasant and smooth - even with a full tank. Although there is the boogie axle on the engine, the machine is very gentle on the ground, mainly because the pull is only on the front two wheels of the boogie.

This machine has a reinforced driveline around the mixer with a duplex chain and sprockets as well as stronger joint, axle and bearings. The engine is a 44 BHP Kubota V1505 turbo 4-cylinder engine, which has a large power reserve for daily work. With its modern design, the engine is also very economical and is probably the one that will work most gently out of all our machines. Although the tank is big, it is very easy to tilt to the side for cleaning or service. In this model, the feed pump is attached to the tank and it moves when the tank is tilted.



ITEM NO. 40100013
 Jasopels Feeding Machine 2000 articulated with mixer, water tank and 2000 l. feed bin

Price EUR

37.825,00

Feed bin side tilt



44 BHP Kubota Engine



Tilting bogie



Specifications

Turning radius 315 cm
4WD, with truck pattern on all six wheels, 12 layers of canvas
4-way adjustable air steered seat
Kubota V1505-Turbo quiet engine with low emission figures
Oil cooler.
Improved mixer
Water dosage
Service friendly and movable feed tank with quick coupling to the feed hose between the front and rear section.

Technical data

Engine	44 BHP Kubota V1505-Turbo, 4 cyl. water cooled diesel
Transmission	Full Hydraulic, 55 l. oil tank with oil cooler
Diesel tank	55 l
Feeding Pump	Fluently adjustable XL toothed wheel pump.
Feed tank	Stainless steel 2,000 l
Water tank	Stainless steel, 50 l.
Measurements	L: 435 cm. H: 169 cm B: 92 cm. Seat height 152-160 cm, sitting height 109-117 cm. Tank height 169 cm

SPARE PARTS FOR FEEDING MACHINES

Item no.	Product description	Price
40200005	1 Grammer air-cushioned seat	*
40200004	Grammer seat with mechanical suspension	*
50100021	Grammer cushion with heat	*
40200015	2 Ergonomic armrest incl. waste bucket	*
50200041	Waste bucket Jasopels 600/700	*
50200040	Waste bucket Jasopels 950/1500	*
40200076	3 Easy grip for feeding hose	*
50100067	4 Feeding hose, soft, blue	*
50100070	Feeding sprout, Ø-40mm	*
50100071	Feeding sprout, stainless	*
50100251	Feeding sprout, stainless	*
50200357	5 Gasabsorber 200N for armrest	*
50200358	Gasabsorber N300 for armrest with Feed Cutter	*
50200360	Angle part for gasabsorber	*
40200016	6 Feed Cutter for armrest	*
50200003	7 Hose white 63 mm by feeding pump - 65 cm	*
50200425	8 Spare parts kit for Jasopels	*
50200426	Spare parts kit for Soffie all types, abroad	*
50200042	Filter kit, big, incl. feeding pump - Jasopels/Soffie 600/700	*
50200043	Filter kit, big, incl. feeding pump - Jasopels/Soffie 950/1500	*
50200427	Filter kit, big, incl. feeding pump - Jasopels 2000	*
40200041	9 Jasopels Farnassist	*
50200252	10 Feeding computer S11	*
50200256	Frame for S11	*
50100148	Solid start relay for S11	*
50200245	11 Encoder for portioning	*
32710011	O-ring for encoder	*
50200008	12 Feeding pump Jasopels/Soffie XL 4 M	*
50200021	13 Nylon clutch sitex 28	*
50200019	Fiber clutch sitex 28, strengthened	*
50200377	Hose pipe 10 mm for water	*
41200006	14 Work lamp LED 12-36V incl. bracket	*
50100126	15 Water pump for regulated feeding 10 l/min.	*
50100127	Water pump for regulated feeding 20 l/min.	*
50100128	Water pump for regulated feeding 22 l/min.	*
50100159	16 Pedal blue Jasopels/Soffie	*
50100160	Effort for pedal	*
50200005	17 Reverse contact - strong	*
50200419	18 Bearing, female	*
50200420	Bearing, Male	*
59400052	Bearing for Jasopels/Soffie 1500 - spreadable	*
40200045	19 Material Box	*
50200422	20 Timer for Mixer - interval mixer	*
50200347	21 Tachometer (extra equipment)	*

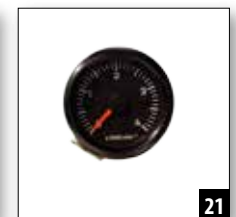
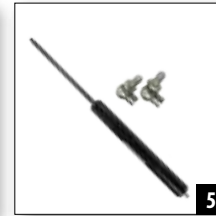

SPARE PARTS FOR FEEDING MACHINES

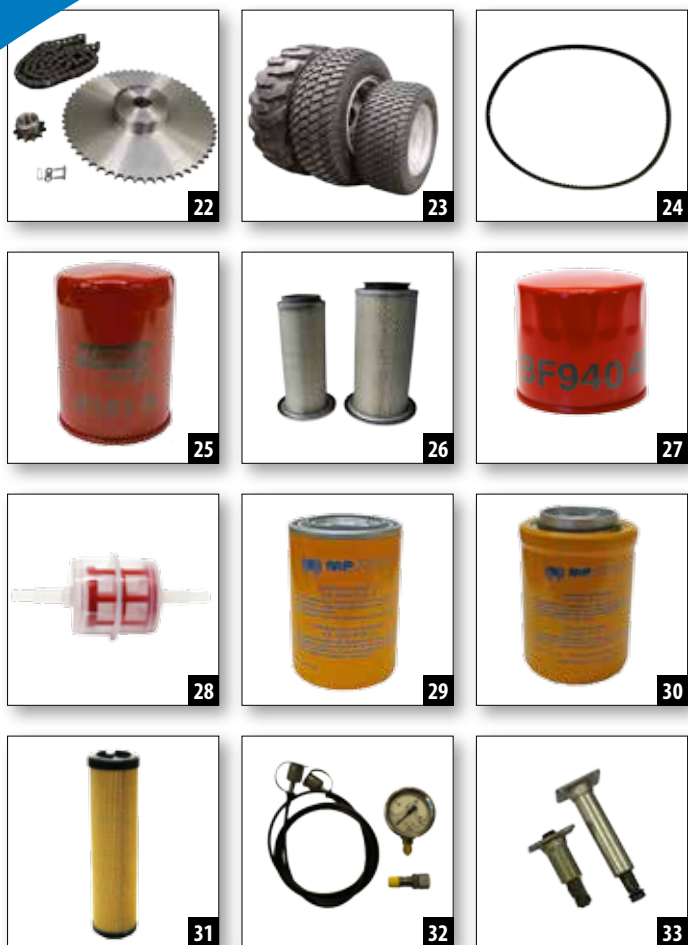

Item no.	Product description	Price
59600111	22 Heavy duty chain 5/8" for mixer	*
59600118	Heavy duty chain 5/8", installation bearing for mixer	*
50200384	Sprocket 57 tooth for mixer	*
50200380	Sprocket 11 tooth for mixer	*
50260386	Sprocket duplex 57 tooth for mixer	*
50200387	Sprocket duplex 13 tooth for mixer	*
59600113	Sprocket 5/8" duplex 10B-2 improved	*
59600114	Heavy duty chain 5/8" duplex 10B-2 improved	*
50500043	23 Complete rear wheel with traction pattern, 6 layers	*
50200416	Complete rear wheel with traction pattern, 12 layers	*
50500035	Complete rear wheel with lawn pattern, 6 layers	*
50500036	Complete rear wheel with lawn pattern, 12 layers	*
50500031	Complete front wheel std. for Jasopels/Soffie 600/700	*
50500033	Complete front wheel wide for Jasopels/Soffie 600/700	*
50200073	24 O-ring for ventialtor Jasopels/Soffie	*
50100219	25 Oil-filter for Jasopels/Soffie	*
50100226	26 Air filter for Jasopels/Soffie 600-1500	*
50200421	Air filter for Jasopels 2000	*
50100218	27 Fuel filter for Jasopels/Soffie	*
50100040	28 Benzinfilter/dieselfilter stor Jasopels/Soffie	*
50200227	29 Hydraulic filter for Jasopels/Soffie	*
50200223	30 Pressure filter for Jasopels/Soffie 950/1400/1500/2000	*
50200221	31 Hydraulic return filter for Jasopels/Soffie	*
50200423	32 Manometer 0-160 bar Ø63 mm 1/4" for mixer control	*
50400110	Manometer screw for mixer control	*
50200424	Sample hose PA 11-2000 for mixer control	*
50400017	33 Steering column 75 mm short model	*

SERVICE

Citing the motto "prevention is better than cure", we would very much like to draw your attention to service and maintenance.

At Jasopels we like to be prepared, but we know that even though we try hard to be ahead of schedule, time moves quickly and our technical staff are overloaded during the pelting season.

In order to provide you with the best possible service, if you already know that some of your machines need servicing, maintenance or repair, please call us to arrange a visit at your pelting plant in good time prior to pelting time.



JASOPELS MULTIUNIT

ITEM NO. 12600090

Jasopels MultiUnit is of great help in the daily work on the farm. It has an electric drive system and easily accessible gear system with 6 gear (3 forward and 3 reverse). MultiUnit can be used for e.g. mink or straw transport, placement of puppies with max. load of 300 kg. Additionally, Jasopels MultiUnit is equipped with a steering wheel placed on the side for easier maneuvering in the shed.

It is possible to purchase additional modules to Jasopels MultiUnit such as:

Item no.	Product description	Price
12600038	Puppies module	415,00
12600039	Shelves module with 3 shelves	370,00
12600040	Shelves module with 2 shelves	270,00
12600041	Straw module	670,00
12600042	Tube module with 64 tubes	710,00
12600043	Tube in Ø 64 cm	Kr. *



NEW

Price EUR
5.345,00

JASOPELS BLUE MOTION

Item no.	Product description	Price
12600091	Jasopels BlueMotion	6.030,00
12600092	Jasopels BlueMotion trailer	2.000,00

Technical data	
Dimensions	L: 150 cm H: 130 cm W: 75 cm – Jasopels BlueMotion
	L: 332 cm H: 100 cm W: 61 cm (90 cm with wheels) – Jasopels BlueMotion trailer
Weight	200 kg – Jasopels BlueMotion
	80 kg – Jasopels BlueMotion trailer
Electrical connection	24 V/12 V outlet
Charging time	12 hours

Jasopels makes your everyday work even lighter. Jasopels BlueMotion can be used both in- and outside. The trailer is easy to maneuver and can make very sharp turns. Moreover, the trailer can be adjusted in height from 210 mm up to 540 mm.

- **Suited to pulling up to 900 kg which equals two full trolleys**
- **Speed: 1 gear: 6km/h
2 gear: 10 km/h + (forward and reverse incl. emergency stop and horn)**
- **Some of the Jasopels MultiUnit modules are compatible with Jasopels BlueMotion trailer**



NEW

JASOPELS GRADING TABLE



Jasopels has developed a grading table which is a useful tool for grading animals on the farm. The table is easy to move around and can be adjusted according to your needs. The grading tray e.g. can tilt up to 45 degrees and can turn around 360 degrees.

The grading table is equipped with a fantastic 8 x 4 W light (colour code 865) – the very same light which is used at Copenhagen Fur, which makes the grading work more effective. The grading table is available with or without additional accessories such as scale or compressor.

Item no.	Product description	Price
12600046	Jasopels Grading Table incl. scale and compressor	3.345,00
12600047	Jasopels Grading Table excl. scale excl. scale and compressor	2.000,00

Technical data	
Dimensions	L: 152 cm H: 164 cm W: 595 cm



FEED SILOS



Item no.	Product description	Price
43100002	Feed silo, stainless, 2.500 l.	*
43100003	Feed silo, stainless, 3.300 l.	*
43100004	Feed silo, stainless, 4.000 l.	*
43100005	Feed silo, stainless, 5.000 l.	*
43100006	Feed silo, stainless, 6.000 l.	*
43100007	Feed silo, stainless, 7.000 l.	*
43100008	Feed silo, stainless, 2 x 2.500 l.	*
43100009	Feed silo, stainless, 2 x 3.300 l.	*
43100010	Feed silo, stainless, 2 x 4.000 l.	*
43100011	Feed silo, stainless, 2 x 5.000 l.	*
43100012	Stairs for stainless silo 2.500 l., 10 steps	*
43100013	Stairs for stainless silo 3.300/5.000 l., 12 steps	*
43100014	Stairs for stainless silo 4.000/6.000 l., 14 steps	*
43100015	Stairs for stainless silo, 15 steps	*

Call us to learn more and get a quote.
Walkway from 600 x 1500 mm to 600 x 5.000 mm in length

JASOPELS LENGTH MEASURING DEVICE

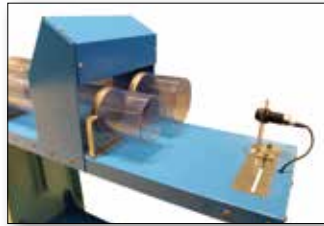

Jasopels has developed a length measuring device which will help you on your farm. The device is available with one or two sensors which measure the mink with ultrasound.

Length measuring device is equipped with one tube for females and one for males.

Item no.	Product description	Price
32300032	Jasopels Length Measuring Device – 1 censor	2.675,00
32300049	Jasopels Length Measuring Device - 2 censors	3.345,00

Technical data	
Dimensions	L: 100 cm H: 130 cm W: 36 cm
Electricity	Battery powered

LENGTH MEASURING DEVICE OPTIMIZES SKIN SIZE

Jasopels Length Measuring Device will allow Fox Farm to improve breeding and get rid of heavy and disproportionate animals.

At Fox Farm mink used to be weighed, but for the current season Jens Peter Larsen decided to invest in a length measuring device.

– During the auction in Copenhagen mink are measured based on the length, so it was clear for us that it had to be done in the same way here, he says.

When they started measurements at Fox Farm, they decided to make their own test to see how the device could be useful.

– First we took some white females, measured them and then pelted them. Afterwards we had a look at them when they were taken off the boards. At that point we could make a decision about the optimal length, that they're going to have, says Jens Peter Larsen

Both males and females were measured and finally weighed, in order to determine what the relation between weight and length is.



**READ ALSO
TORBEN MADSENS'
OPINION
ON PAGE 35**

TAKE PART IN A TRAINING SESSION AND MAKE MONEY!

With the Jasopels pelting machines work is performed quickly and correctly. This way efficient working conditions and high quality of the final product are ensured.

Jasopels are now stronger than ever in their efforts to offer fur farmers the best solutions for skin handling, whether what you want is a solution for the entire process or just individual machines.

Jasopels provides effective solutions for all phases of the process (putting the animals down, skinning, scraping, stretching and drying) until the moment when the skins are in the storage room, ready to be shipped. Every step is performed in the professionally best possible way.

The machines are designed and developed based on many years of experience in the fur industry.

In our development department accomplished professionals work all year long to develop and improve the machines so that we can always offer you the best products on the market.

We test the machines thoroughly before they are released for sale in order to make sure that you get products that are all of high quality. At the same time we focus significantly on achieving the best possible working functions.

In order to make work even easier and more efficient, we have developed a number of unique tools and machines over the years. Their task is to transport mink skins, bodies and sawdust during the pelting process so that everything can be done in a single operation cycle, with great efficiency and with work satisfaction as a result.

Jasopels offers all users of new Jasopels machines practical training aimed at allowing them to get the most out of the pelting process and helping them become familiar with the machines before pelting season.

Last season a couple hundred mink breeders agreed to participate in Jasopels' practical training in the use of the Jasopels WRAP Machine T5 Maxi Stretch, Jasopels Fleshing Machine T6 and Jasopels Pelting Robot XXL.

It gives you overview and energy to keep the pelting center running effectively – e.g. during peak load periods, when it is necessary to change a spare part – so that you can move the production process forward as soon as possible.

The courses will take place from the 10th to the 14th of October 2016.



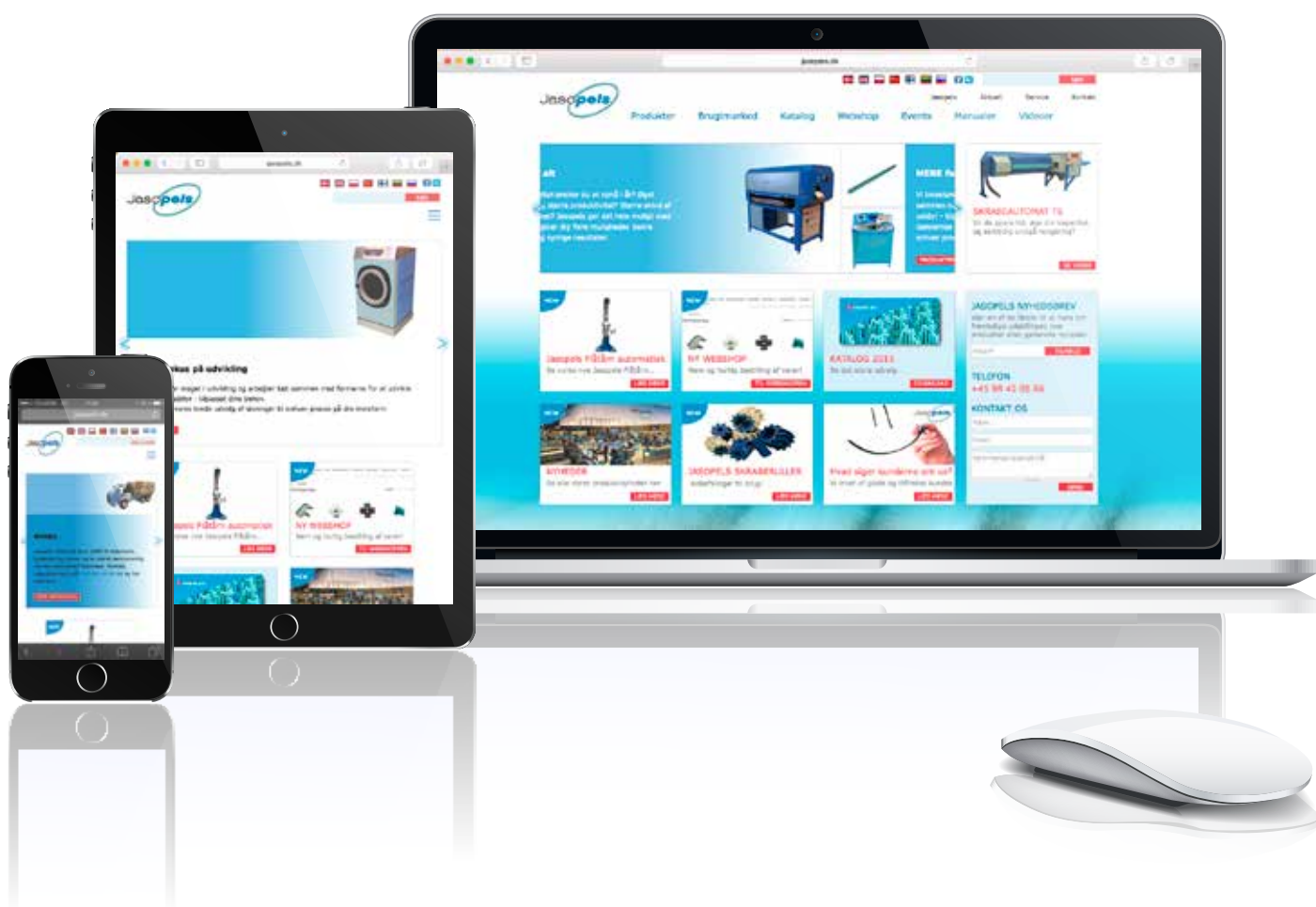

GET AN OVERVIEW OF WWW.JASOPELS.COM

We are always very happy to advise and meet our customers face to face to find the right solutions and products for them. Using our Jasopels website you can get inspiration for solutions that will help you in your work on the farm.

The site presents all our products with descriptions and informative illustrations, as well as relevant news about current events, courses, open house days and thematic days.

Jasopels is an internationally oriented company and therefore the site, besides Danish, is also available in English, Polish, Chinese, Finnish, Lithuanian and Russian. Remember that in our webshop you can order spare parts and farm items 24 hours a day all year round.

Manuals for all products

At Jasopels we send manuals with each machine that we sell and we keep updating our documentation. In the unlikely event that you received a machine without an attached manual, you can always find it on our website.

Go to www.jasopels.com and click "Manuals". You will see the manuals for all machines. The advantage of using an online manual is that you will always find its latest version.

Second-hand machines

If you need a machine, and you could do with a second-hand one, it's worth checking out our second-hand machine directory that can be found on our website. We update it continuously, so it's good to keep an eye on the content.

You may use our website to find the person from our staff that you want to talk to. Here there is all contact information including their picture and e-mail. It could, for example, be a member of our sales team, who is always ready to provide answers to your questions and can meet you any time.

Item no.	Product description	Price
32500003	1 Jasopels Trolley for bodies - 9 adjustable shelves L.: 215 cm H.: 194 cm W.: 95 cm	1.610,00
32500004	Jasopels Trolley for bodies - 8 adjustable shelves, with extra storage. Dimensions for the shelf: L.: 200 cm W.: 46 cm	1.610,00
43200004	2 Gasbox w/Gasoline engine w/electric start	*
43200005	Gasbox, w/electric start (Co2)	*
43200008	Conveyor for Gas box 225 cm. incl. wheels	*
43200009	Conveyor for Gas box 285 cm. incl. wheels	*



When using a Gas Box, a Conveyor and a Body Drum, you will experience higher efficiency in the process of putting the animals down.



XL DRUMS PROVIDE FLEXIBLE WORKING DAY

With two new Jasopels XL drums Torben Madsen has gotten much more flexibility than before, and at the same time a new measuring instrument turned out to be very useful when selecting the breeding males.

Torben Madsen is a thriving entrepreneur, who for the past 20 years has gradually developed his mink farm which today consists of 18.000 females. He also manages a farm with 7.000 females, together with a former coworker.

– Our common goal is to produce some good mink and to gradually sell lots of breeding animals. We do our best to keep the high quality on every stage of our work, but this means that we must have the right stuff and the right sparring partners, explains Torben Madsen, the proprietor of TM Mink.

XL drums save money

In 2015 there were 25.000 breeding animals sold and 100.000 mink pelted at TM Mink. Until recently, the high number of animals meant that they had to be put down from morning till evening so that the drums could keep up with work.

– That is why we decided to buy Jasopels XL drums last year and they have been of great help. Now we can start putting down at e.g. 2 p.m. and we are done at 4 p.m., emphasizes Torben Madsen.

Therefore the day can be planned effectively, with ca. 300 animals in each drum at a time.

– Whichever way you look at it – we have saved money on these drums, concludes Torben Madsen.

Filling sawdust is carried out manually and the drums are equipped with a small suction unit, which effectively removes the dust.

Division into three groups

In the current season a Jasopels Length Measuring Device has been used for the first time at TM Mink. It measures the length of the mink with a ultrasound sensor.

– All of our breeding animals go through this machine; it's an obvious advantage to know the length.

– If you only use weight, it can happen that you come across a male which is 51 cm long and another one which is 46 cm, but they both weigh 4 kg. The one which is 51 cm long is usually of the better quality, concludes Torben Madsen.

During the pelting season the mink get divided into three categories according to the quality – those that will be used for breed, those that will be sold and the rest, which will be pelted.

Better breeding with length measuring device (page 31)

If you decide to invest in a length measuring device, you should let the same employees carry out all the measuring, recommends Torben Madsen.

– You should get the same people to measure the mink, because there is a difference in the way people hold the animals – it is easy to get 2 cm difference, all depending on who is measuring, says Torben Madsen.

In his opinion you should be prepared for some extra work, but that is in line with the company philosophy.

– If we take 100 males, 4 kg each, it will turn out that there are 5 – 7 animals which would be discarded for breeding purposes because they are too short. Many breeders will for sure say that this is not a sufficient reason for carrying out the measurements, but not us. We are not an "average" farm. We are the farm which makes the best mink, concludes Torben Madsen.



The new family of Jasopels' effective drums has already become highly appreciated by both Danish and foreign fur farmers. This is, of course, a result of many factors. The success is by and large due to the fact that apart from being effective and reliable, the machines have been designed with the utmost attention paid to both safety and the working environment.

It is characteristic for all new Jasopels drums that the rotating core is encapsulated. In this way we made sure that the user cannot get to the moving parts unintentionally. The traditional belt drive is no longer used in the new drums. This means that you get a drum without tensile stress and you save money on wearing parts. The large wheels are driven by direct drive with a soft-start feature, which ensures smooth operation, and at the same time the absence of belts makes the machines very quiet. We have, of course,

equipped the larger models with the latest digital technology, which makes programming very easy.

Put suction on your drums to improve the working environment.

Regardless of how good and expensive sawdust you are using, there will always be varying occurrences of what is called dangerous dust, which is basically dust smaller than 0,063 mm

Dust is as such very light and it is practically invisible to the naked eye. All wood contains a certain amount micro-organisms, yeast and mould fungus, which may cause serious respiratory diseases.

If you want to improve the working environment in your pelting center, we recommend that you install suction devices with your drums. The machinery itself is placed outside of the pelting center in order to eliminate both noise and dust from the workplace.

JASOPELS BODY DRUM XL

ITEM NO. 32400013

- **New tumbling method**
- **Reliable construction**
- **No compressed air necessary**
- **Movable electric box**
- **Fast emptying**
- **Additional cleaning of bodies**
- **Very large capacity (About 300 males/450 male/female)**
- **Improved emptying system**
- **Emptying height – 81 cm**



Price excl. suction device
EUR

17.555,00

Technical data	
Dimensions	L: 400 cm. H.: 200 cm. W: 180 cm.
Electricity	3 x 400 Volt N + PE
KW peak	6 kw.
Connection	CEE 16A plug

JASOPELS BODY DRUM

ITEM NO. 32400012

- *New tumbling method*
- *Reliable construction*
- *No compressed air necessary*



Technical data	
Dimensions	L.: 240 cm. H.: 210 cm. B.: 175 cm. Ø 120 cm. closed.
Electricity	3 x 400 Volt N + PE
KW peak	3
Connection	CEE 16A plug

Price excl. suction device EUR
12.150,00

JASOPELS BODY DRUM WITH SLIDING DOOR

Fill the drum with mink and start it. You can set the tumbling time yourself. When the set tumbling time is up, the drum will automatically remove the mink and the sawdust will remain inside the drum.



Technical data	
Electricity	3 x 400 Volt + N + PE
Air	0,05 l/min and 8 bar
Dimensions	L.: 230 cm. H.: 182 cm. W.: 124 cm.
Connection	CEE 16A plug + Air

Item no.	Product description	Price
32400002	Jasopels Body Drum with sliding door, right	8.775,00
32400003	Jasopels Body Drum with sliding door, left	8.775,00
32800018	Safety kit, wire set	670,00

Price EUR
8.775,00

NEW

- Automatic moving of sawdust from skin drum to skinning line and fleshing machine together with automatic moving of sawdust from leather side drum to waist container
- Moves sawdust around the pelting center with help of chain
- Minimizes the involvement of staff in handling sawdust
- Farmer can save several working hours

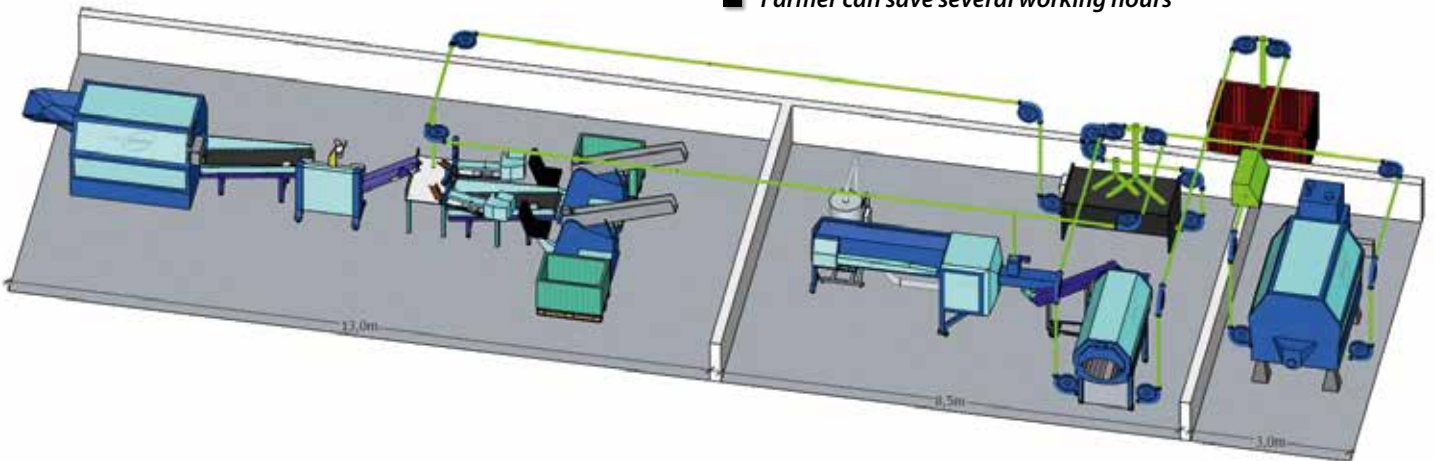

SKIN MOVING SYSTEM

ITEM NO. 32500043

Together with the Self-Emptying Skin Drum the system can carry out the following working processes:

- Automatically move skins from the fleshing room to a silo placed above the drum
- Move the skins from the silo under the drum to the pinning room/pinning machine
- The automatic control monitors the rest of the procedure after tumbling is finished
- Move sawdust from the drum via a buffer silo to the container above the Fleshing Automat
- Time-saving, saves up to 75% of expenses connected with the drum operator's wage

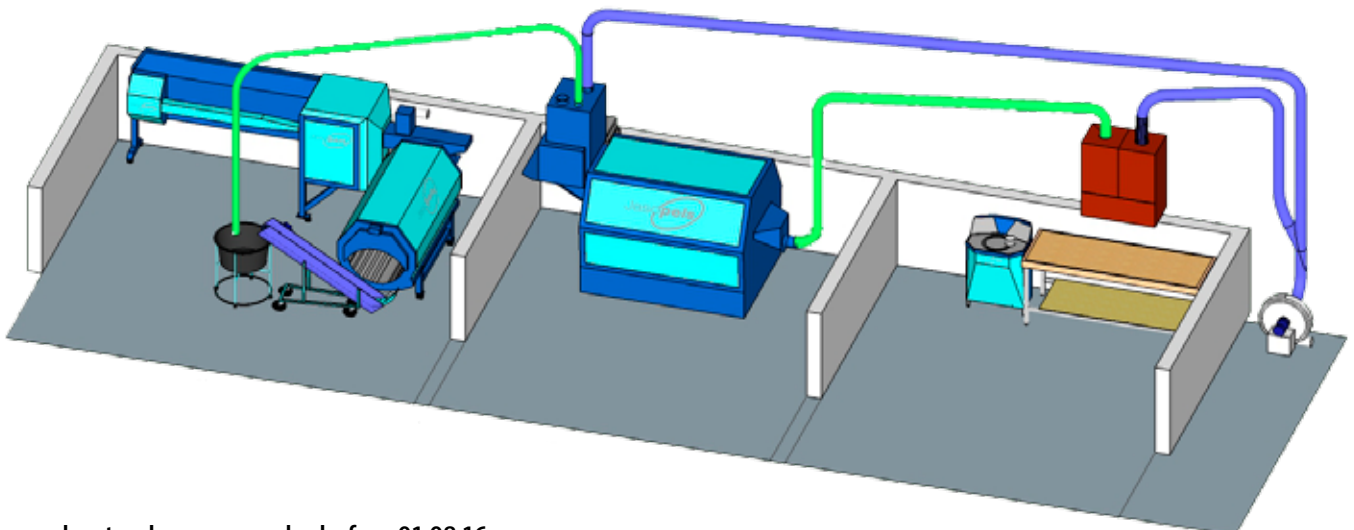

Remember to place your order before 01.08.16 if you want the machine delivered in 2016.

JASOPELS SAWDUST HEATER

ITEM NO. 32500058



The "good old" Sawdust Heater that is always in great demand – now in a new and modern version.

The machine has a large capacity. It can take approx. 5 bags of sawdust at a time. Sturdy construction. Equipped with large rubber wheels.

Technical data

Electricity	3 x 400 Volt + N+PE, 3,75 kW
Connection	CEE 16 A plug
Dimensions	L: 215 cm. H: 190 cm. W: 75 cm.
KW peak	3,75

Price EUR

6.745,00

JASOPELS SKIN DRUM

ITEM NO. 32400011

- *New tumbling method*
- *Reliable construction*
- *Can be connected to the Skin Moving System*
- *No compressed air*
- *Excl. Skin Moving System*



Technical data

Dimensions	L: 370 cm. H: 180 cm. W: 170 cm. Ø 120 cm Closed
Electricity	3 x 400 Volt N + PE
KW peak	3
Connection	CEE 16 A plug

Price excl. suction device and skin moving system EUR

12.150,00

JASOPELS SKIN DRUM WITH SLIDING DOOR



A time saver that you can really feel!

- The skins are tumbled in a closed drum
- Switches to net drum automatically
- The drum removes sawdust itself
- Automatic replace furs with skins
- Air-operated loading lid

Price EUR
9.450,00

Technical data	
Dimensions	L: 272 cm. H: 199 cm. W: 126 cm.
Air	2 l/min 8 bar
Electricity	3 x 400 Volt + N + PE
KW peak	1,5

Item no.	Product description	Price
32400009	Jasopels Skin Drum with sliding door, right	9.450,00
32400010	Jasopels Skin Drum with sliding door, left	9.450,00

SUCTION DEVICE FOR JASOPELS BODY DRUM AND SKIN DRUM

ITEM NO. 32200025



Price incl. pipes EUR
2.030,00

Technical data	
Measurements	L: 135 cm. H: 250 cm. W: 66 cm.
Electricity	3 x 400 Volt + PE
KW peak	2,2
Connection	CEE 16 A plug

SPARE PARTS FOR DRUMS

 32800021 Safety set for Body Drum	 32800022 Safety cover for wheels	 51500010 Driving wheel	 51500053 V-belt B167, inside measure 4242 mm	 51500086 Wheel for Jasopels Skin Drum	 52800011 Wheel for Jasopels Leather Side Drum
 52900033 Eccentric lock no. 105	 59200339 Pizzato ISO electronic stop 1 NC + NO	 59200342 Pizzato emergency contact 2 NC+1 NO slow	 52800016 Support wheel Ø200 w/6204 bearings	 52900003 Support wheel Ø200/Ø20	 51500104 Electrical swivel joint set, new model
 51500120 Brush holder for Skin drum	 51500122 Swivel joint 1/8 x 1/8	 59100045 Swivel elbow fitting RTJ 1/8 x 1/8	 59100104 Magnet coil 240V/50Hz for M pilot MB25	 59100106 Control element for magnet coil M2 NC	 59100163 Valve 5/3 1/8 NC 220/50 for Skin drum

CONVEYOR BELT FOR BODY DRUM

The Conveyor Belt is supposed to be placed right by the Body Drum. It needs to be placed in such a way that the mink bodies, as they leave the drum, are fed directly onto the conveyor belt, which thanks to a control module will transport them at the same tempo as that of the slicing and skinning performed by the Slicing Machine/Pelting Robot.

Item no.	Product description	Price
32500032	Conveyor belt, 50/150 cm, incl. control panel	2.690,00
32500033	Conveyor belt, 50/200 cm, incl. control panel	3.365,00
32500034	Conveyor belt, 50/300 cm, incl. control panel	4.040,00
32500038	Conveyor belt, 100/300 cm, incl. control panel	6.070,00
59200308	1 Photo Sensor Ø18, angle reflection	*
59200312	2 Reflector tapes, 50x1000mm	*

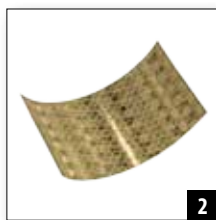

CONVEYOR BELT

Increases the capacity by over 30%

Place the Conveyor Belt under the Slicing Machine. The conveyor Belt transports the mink to the Body Hook. Suitable for Slicing Machine T2 and T3.

Item no.	Product description	Price
32500009	Conveyor belt 2 m excl. stand	1.340,00
32500011	3 Conveyor belt for Slicing Machine T3, 2,5 m excl. stand	1.595,00
32200037	Conveyor belt for Leather Side Drum with stand	1.610,00
52100054	Conveyor belt, loose, 1,5 m	275,00
52100056	Conveyor belt, loose, up to 2,0 m.	340,00
52100059	Conveyor belt, loose, up to 2,5 m	465,00
32500018	4 Tub trolley with 4 swivel castors/round black bowl	185,00



CONVEYOR BELT FOR SKINNING MACHINE T3/T4

Place the Conveyor Belt after the Skinning Machine. It will then transport the bodies to the container. Excl. stand.

Item no.	Product description	Price
32500023	Conveyor belt, 15 x 300 cm	2.700,00
32500024	Conveyor belt, 15 x 400 cm	3.475,00
32500025	Conveyor belt, 15 x 500 cm	3.750,00
32500026	Conveyor belt, 15 x 600 cm	3.880,00

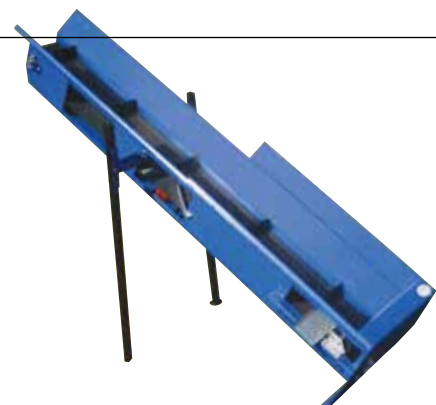

Jasopels paw cutter is a fast-working and effective device with a very high capacity. It is easy to operate so you do not need to waste time on training.

Apart from a uniform cut you have a possibility to make an entry control as the paw cutter is equipped with a display which stores all the relevant data.



PATENTED

Price incl. 2,5 m conveyor belt
EUR

10.730,00



Technical data

Dimensions	L: 767 cm H: 1332 cm W: 842 cm.
Electricity	3 x 400V + N + PE
KW peak	0,3
Connection	CEE 16A outlet + air

NEW LOCATION IN POLAND

IMPROVED CAPACITY AND EFFECTIVENESS

In 2016 Jasopels opened a new modern plant in Oborniki, Poland and hence collected the whole production in one place.

Jasopels has had production facilities in Poland for more than 10 years. In the last few years the production took place in three different sites, which are now gathered under one roof.

– Here at Jasopels we have a strong faith in the future and the necessity to improve both our products and the company. That is why we have decided to build a new modern facility in Oborniki, says Poul A. Bach, CEO at Jasopels.

The factory will be opened in 2016 and will bring benefits to both customers and employees.

– For our customers the new facility means that we will continue to improve the quality and produce new quality products using state of the art technology and modern facilities, reckons Poul A. Bach.

Better efficiency and job satisfaction

The new factory will give Jasopels employees a powerful boost.

– By gathering all activities in one place, we can arrange the work in a better way and get the facilities and devices which will give our employees greater job satisfaction, says Poul A. Bach.



Another advantage of gathering all activities in one place instead of three, which Poul A. Bach sees, is improving the logistics and communication around the product, both internal and external.

– Above all, Jasopels will now have the facilities which will fulfill the requirements of the market regarding the delivery of the best solutions to mink breeders at a global level, Poul A. Bach notes.

EASY LAUNCHING A NEW PELTING CENTER WITH JASOPELS PELTING LINE

In 2015 Kenneth Dalentoft inaugurated his own pelting center with Jasopels pelting line, which had a smooth start despite new employees and new facilities.

A steadily increasing production made Kenneth Dalentoft from Skærlund Mink i/s establish his own pelting center for season 2015. Right now he has 4.500 females in six different color types. During the first season 23.500 mink were pelted, and that number should soon increase to 28.000.

– Given the fact that everything was new, I can say that it went easier than expected. We had some start-up difficulties and during the first days we only pelted 1.200 – 1.300 mink daily. I thought ‘this here is gonna be tough’, but after 3-4 days we reached the level of about 1.800 – 2.300, says Kenneth Dalentoft.

In his opinion, the success is grounded in a number of factors, such as well-trained employees and a pelting line, which turned out to be stable and easy to work with.

Simplicity that can be expanded

In the pelting center there are 10 employees, who work six days a week. The majority of them had never work in the pelting center before.

– What we had in common though, was the fact that all of us had taken part in the training organized by Jasopels, so we were prepared. It also meant that it was easier for us to overcome those difficulties we came across, and usually we needed only phone support, says Kenneth Dalentoft.

The pelting center consists of Jasopels Fleshing Automat T6, Jasopels Body Drum, Jasopels Slicing Machine T4 XL, Jasopels MaxiHook T5, Jasopels Skinning Machine T4 XL, Jasopels Skin Drum, Jasopels Wrap Machine T5 Maxi Stretch and Jasopels Skin Cleaning Automat T5. Additionally, there are skin moving system and sawdust transport system. For Kenneth Dalentoft the important thing was the combination of high capacity with low risk.

– The crucial thing for me is not to pelt the high number of mink, but to take as many as it is possible while maintaining the high quality.

– That is why we picked up those machines. There are many different machines available on the market, but Jasopels pelting line



fits well with the way we work; it is easy and cheap to expand, explains Kenneth Dalentoft.

Help with designing

From the very beginning Kenneth Dalentoft was convinced that it was Jasopels that should deliver the pelting line.

– I received a great deal of support from Jasopels during the design phase. They came up with a concept proposal of how the machines should be arranged and, after a few small adjustments, this project was carried out, he says.

One of the advantages of building from a scratch was that many details could be thought over before the project was put into life.

– It means that we were able to arrange everything in the most efficient way possible. From the moment the animals arrive at the pelting center we have a smooth flow so ways are not being crossed. The only place where it happens is the point where the skins are being packed and leave the room, emphasizes Kenneth Dalentoft.

The start-up phase coincided with the beginning of the high season, and at this point a praise must be given to the service team.

– A service technician came a couple of times during the season, but otherwise we were able to cope with the smaller issues over the phone. It helped a lot that we took part in the training because many problems could be solved over the phone, concludes Kenneth Dalentoft.



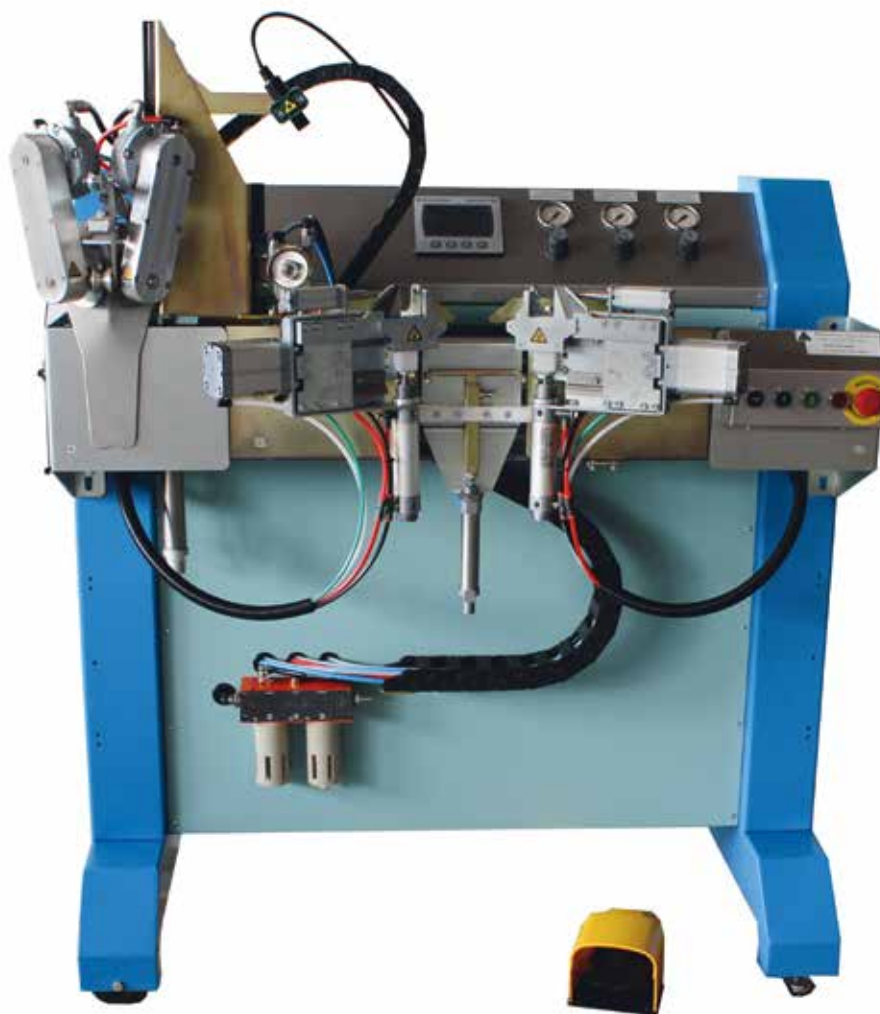

Price EUR

19.585,00



32100005 Pawcut Upgrade

Jasopels Slicing Machine T3 XL/T4 XL with laser for marking of cross cut.

This model has an increased stretch length and V-cut. The machine's process time is approx. 5 seconds per animal.

With a display, where you can read out cycle time and other relevant production data. Quick switching between males and females. Extra air regulator for setting the stretch pressure for both males and females. 100% correct triangle cut. Streamline your workflow by placing a conveyor belt under the Slicing Machine.

Technical data

Electricity	1 x 230 Volt + N + PE.
Air	600 l/min and 8 bar
Dimensions	L: 120 cm. H: 120 cm. W: 65 cm.
Connection	230 Volt plug + Air

Item no.	Product description	Price
32100003	Jasopels Slicing Machine T3 XL	17.555,00
32100006	Jasopels Slicing Machine T4 XL	19.585,00
32100005	Pawcut upgrade	2.700,00



JASOPELS PELTING LINE

It's well known that errors in the pelting process make the subsequent processing steps harder. So it's essential to eliminate as many of these errors as possible. A pelting line consisting of Jasopels machines – a Slicing Machine T4, two MaxiHooks, and two Skinning Towers – makes it easy to maintain the highest level of care at every stage. "Before, our production was about 5000 pieces daily. Now it's at least 7000," says Loes Janssen from Janssen Farming Group.

You decided to replace the whole pelting line at once with Jasopels machines, a Slicing Machine T4 XL, a MaxiHook, and a Skinning Tower. This stage of the production process demands great precision. How is the new line working out?

At every stage of the pelting process there can be errors which cost a lot later. It's important to eliminate as many of these errors as possible. The most important aspect is precise cuts, like the kind that the Jasopels machine makes. Our previous machines didn't make cuts as precisely or quickly every time. One big advantage of the MaxiHook is how efficiently and smoothly it is loosening the hind legs. Our operators also like the new Skinning Tower because it is very "clean" in use.

Replacing the whole line must have been costly. Why did you decide to make such a serious investment?

We wanted to see how the whole pelting line worked. It wasn't a problem to do that here at our place, because Jasopels let us test the equipment. We wanted our production to be more efficient, and that's exactly what happened thanks to Jasopels.

How much has your efficiency increased?

Previously, our production was about 5000 pieces daily. Now it's at least 7000 pieces.

Do you work exclusively on Jasopels machines?

No, not exclusively. Currently, we have one pelting line from Jasopels, and the rest of the machinery from another manufacturer. But our operators prefer to work on the Jasopels machines. It's easier and safer for them. All of the machines are highly computerised. That's probably the best recommendation.

How many people does it take to operate the whole line?

We need five people to operate the line. If we had chosen a Robot, we could probably do it with one person. But in order to use the Robot, you need to undergo several days of training. With a line, the operators only need a few hours to learn everything.

You have to know all facets of the business. How do you manage with the machines? Are they hard to handle?

The machines, especially the ones from Jasopels, are getting bigger, faster, and more computerised. When we need help, a service person from Jasopels comes and hooks up a laptop to the machine – it's amazing! Mastering the machine itself is quick and easy.

You already have some experience working with the line. Have you got any tips for other breeders?

In the case of the MaxiHook, you have to remember to adjust the force to a given animal, because each one is a little different. That's all.

SPARE PARTS FOR SLICING MACHINE T3 XL/T4 XL



32710001

Paw holding brick, left



32710002

Paw holding brick, right



32710003

Knife for paw cut, left



32710004

Knife for paw cut, right



32710005

Circular knife for T2 Ø 50 mm



32710013

Knife for paw cutting right saw 2014



32710014

Knife for paw cutting left saw 2014



32800046

Spare part kit Slicing Machine T3



33900028

Grindstone



51200053

Paw cut cylinder - Left



51200055

Paw cut cylinder - Right



51200085

Knife holder



51200088

Air engine cross cut



51200091

Knife, round, Ø 50 mm



51200092

Knife, round, Ø 50 mm High Speed Steel



51200119

Knife, round, Ø 80 mm



51200120

Knife, round, Ø 80 mm High Speed Steel



51200133

Paw plate T3 2006, new left



51200134

Paw plate T3 2006, new right



51200150

Belly paddle XL - Slicing Machine T3



51200172

Air engine Slicing Machine T3 - Left



51200173

Air engine Slicing Machine T3 - Right



59100295

Cylinder Ø 32x50 mm



59200001

Laser beam for cross cut marking



59400021

Glasier bearing PAF 0608 for paw knives



59400093

Ball bearing Ø15 x 32 x 9



59400095

Ball bearing Ø12 x 28 x 8 steel seal 6001 ZZ



59400155

Slide bearing



59600065

Gates toothed belt GT3 5MGT 425-09



51200193

Shock absorber WS-M 0,2-3 to T3/T4



51200222

Counter blade to the new paw cutting right to T3/T4



51200223

Counter blade to the new paw cutting left to T3/T4

SKINNING TABLE WITH CONVEYOR BELT

ITEM NO. 32100020

The conveyor belt is controlled by a sensor so that there is always a mink ready at the outlet. This is highly time-saving for the skinning personnel.
Incl. steering with sensor.

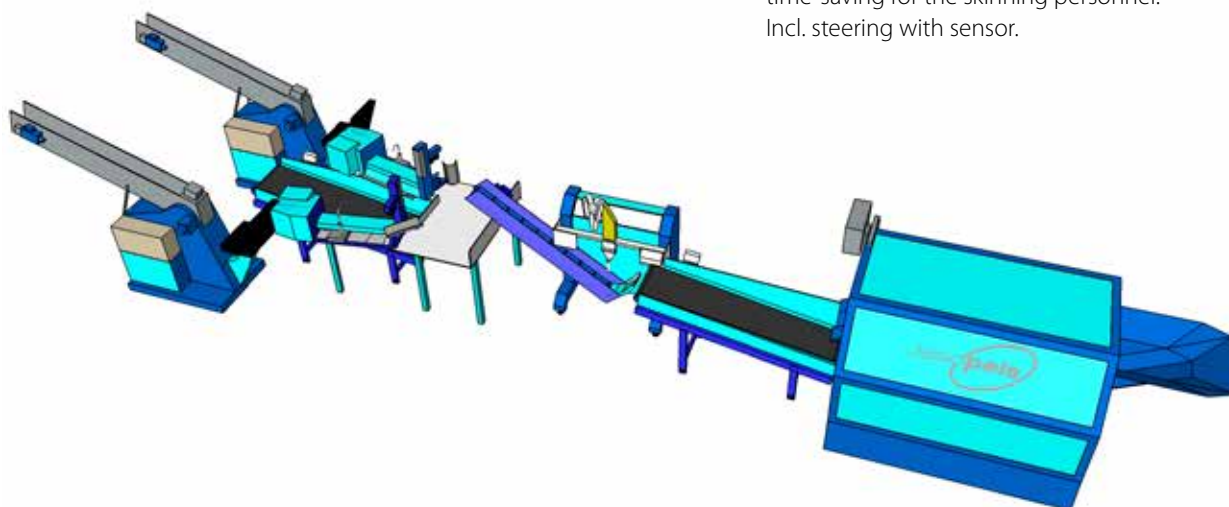

SKINNING TABLE WITH A STAINLESS TABLETOP

ITEM NO. 32100019

Skinning table with a stainless tabletop includes 1 side table and 1 conveyor belt.

Additional side table can be bought extra.

Price EUR

5.810,00



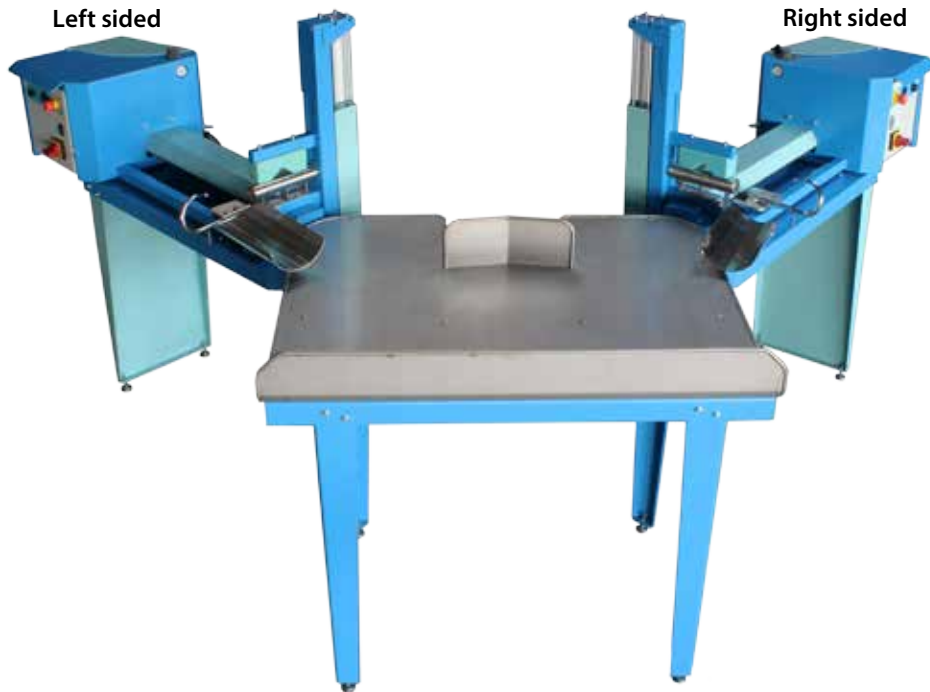

NEW
Possible in both a left and right model

MaxiHook gives you the possibility of changing the speed, so even the toughest skins remain intact.

This helps making the rest of the skinning process much easier.

- Pulls evenly and protects the skin
- Adjustable speed
- Optimized for larger minks

Technical data	
Air	8 bar, 2 l./cycle.
Dimensions	L: 130 cm H: 66 cm B: 50 cm
Electricity	1 x 230 Volt + N + PE
Connection	230 V plug – AC/DC relay + Air
KW peak	1,1

Item no.	Product description	Price
32100009	Jasopels MaxiHook T5, right	6.067,00
32100010	Jasopels MaxiHook T5, left	6.067,00

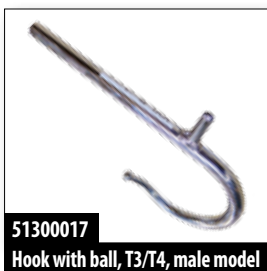

JASOPELS SKINNING MACHINE T4 XL

ITEM NO. 32100011

This machine is easy to use and it is also available with an automatic body remover. Improved Skinning Machine and shoulder holder.

The stretch length has been increased by 250 mm. If the machine is placed together with a body remover and a small conveyor belt that transports the bodies to a container, the fur flow is better and the entire working process is optimized.

Price EUR
7.420,00

The price includes pneumatic knife and hanger.



Technical data	
Electricity	1 x 400 Volt + N + PE
Air T3 XL	600 l/min. og 8 bar.
Air T4 XL	600 l/min og 8 bar.
Dimensions	L.: 120 cm H.: 120 cm W.: 65 cm
KW peak	0,3
Connection	CEE 16 A plug + Air

JASOPELS SKINNING MACHINE T11

ITEM NO. 32100035

A new and efficient skinning technique that takes over the hard, physically demanding work and ensures quick and accurate completion of the job, regardless of how large the minks are.

Skinning Machine T11 has a seat that ensures an ergonomically correct working position and eases the job for the operator. Skinning Machine T11 can be easily and safely operated with its two foot pedals. In a single procedure, the skin is pulled off and put aside, while the body is transported away on the conveyor belt.

- **Large capacity**
- **Ideal for large animals**
- **Ergonomically correct work posture**
- **Built-in conveyor belt**

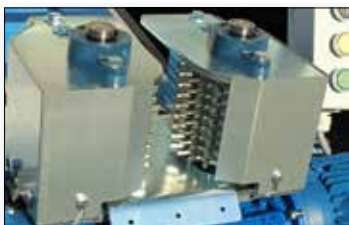

Technical data	
Air	2,0 l/min and 8 bar
Electricity	3 x 400 Volt + N + PE
Dimensions	L.: 240 cm H.: 175 cm W.: 80 cm
KW peak	2,78
Connection	CEE 16 A plug + Air

**The price includes
pneumatic knife and hanger EUR**

13.425,00



NEW SKINNING TOWER SAVES PHYSICAL POWER OF EMPLOYEES AND MAKES THEM TO STAY

New Jasopels Skinning Tower Automatic guarantees easier and far less physical work during the season

It was elderly workers who were the main reason for Henning Henriksen to invest in the new Jasopels Skinning Tower Automatic in the previous season.

– Workers who help me in a fur season are, like me, around 50 years old. So if I wanted them to skin for another five years, there was a need for relief.

– The old skinning tower was physically demanding, whereas the new model can even take the skins directly without pulling the skin first, which makes work far less exhausting, he says.

Henning Henriksen had previously invested in the Jasopels Skinning Machine T11, which he was very pleased with.

– It is a machine I indeed have been very happy with, but the new model hits the bull's eye because it is not so demanding, he concludes.



It is also worth mentioning that the machine fits in the pelting center very well thanks to its dimensions.

– The machine is quite compact which I see as an advantage. It means that we can keep the whole pelting in one place so we don't need to go very far from one task to another, says Henning Henriksen.

The new skinning tower means also a change to an electric system.

– It is very important because now we can control the process much better due to much more dynamic pull of animals and skins, emphasizes Henning Henriksen.

Evening work throughout the season

Henning Henriksen has 2.400 females and pelted 13.000 minks in the previous season. From this point of view he sees Jasopels Skinning Tower Automatic as the right choice.

– It is also very interesting in terms of price. Taking into consideration the number of animals we need to skin, the machine fits in well. We are actually considering buying one more tower, says Henrik Henriksen.

Unlike many other farmers, Henning and his employees work in the evenings.

– Our workers come after their regular working hours and we must have 6-700 skins ready, therefore we are little pressed for time. We try to keep Sundays free. On Saturdays we work from 7 to 15 and get 1.200 skins through, explains Henning Henriksen.

He admits that it might be slightly more expensive to work this way.

– It is nice that I can get help from the same people and don't need to search new ones every year.

– Thanks to their great experience, my workers can repair and service the machines themselves. They take the initiative, without asking first. It is a huge advantage, emphasizes Henning Henriksen.

JASOPELS SKINNING TOWER

ITEM NO. 32100013

The Jasopels Skinning Tower is easily operated and is based on well-known skinning techniques.

In order to increase the efficiency of the machine, an electrical motor and spindle has replaced the former pneumatic. Further this improvement ensures an even pull as well as relief to the operators.

- **Even pull and relieve to the operator**
- **Easy operation**
- **No compressed air supply necessary**
- **Takes nearly no space**



Technical data

Electricity	3 x 400 Volt + N + PE
Dimensions:	L: 126 cm H: 214 cm W: 80 cm
KW peak	2,2
Connection	CEE 16 A plug – AC/DC relay

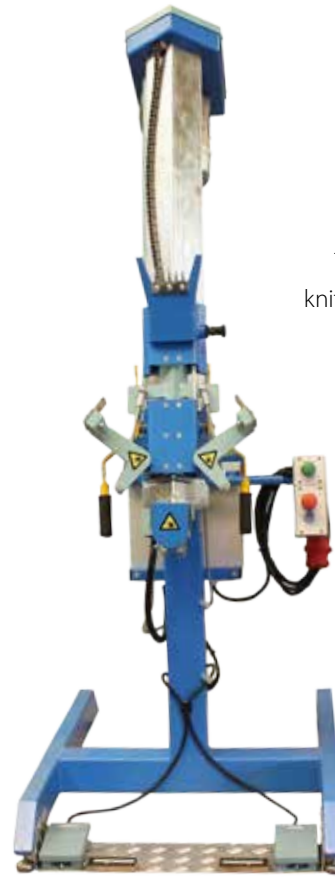

Price EUR

6.070,00

The price includes pneumatic knife, hanger and counterweight

JASOPELS SKINNING TOWER AUTOMATIC XL

ITEM NO. 32100041

This machine is entirely new. Although developed from the very popular machine above, the JASOPELS Skinning Tower Automatic XL is able to skin mink, which are 3-4 sizes bigger, as the machine is 40 cm's longer in total skinning length. Moreover, the machine grasps the skin without the operator pulling first, which ensures optimal ergonomics.

- **No manual pull necessary**
- **Takes big males itself**
- **Even pull and relieve to the operator**
- **No compressed air supply necessary**
- **Takes nearly no space**



Technical data

Electricity	3 x 400 Volt + N + PE
Dimensions:	L: 135 cm H: 220 cm W: 82 cm
KW peak	2,2
Connection	CEE 16 A plug – AC/DC relay



NEW

Price EUR

7.420,00

The price includes pneumatic knife, hanger and counterweight

SPARE PART FOR SKINNING MACHINE

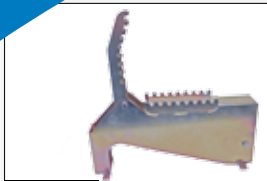

32800006
Kit for rebuilding the holder of T3 Skinning Machine

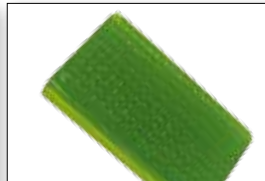

51400015
Skin holder, rubber, 13x62x96

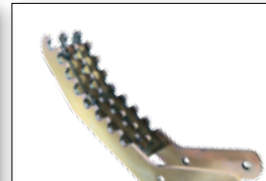

51400073
Arm for holder, knuckle model



59100139
Foot pedal 5/2, yellow



32800048
Spare parts kit BS Hydr. Skinning Machine



32100025
Pneumatic knife, straight model



32100034
Pneumatic knife, angle model

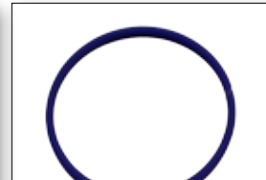

32710011
Drive belt for pneumatic knife straight/angle, blue



32710006
Knife, round Ø50 x 16 x 1 mm



51200092
Kniv rund Ø 50 mm High Speed Steel



51400058
Hydraulic Station 1.5 kW electric/oil engine, 220V



51400055
Pneumatic controlled Cetop valve



31200027
Complete silencer for air knife



31200006
Head of the head cutter with click system



31200007
Mounting kit for head cutter

SPARE PART KITS

NEW

Now spare part kits for Jasopels Feeding Machines.



We all know how costly it is when machines go on strike during production – this also happens in pelting centers where any problems in the production flow should be solved as soon as possible. Jasopels therefore recommends getting the spare parts kits. The experience tells that it is often a spare part which must be replaced and often it can be found in the spare parts kit. By having a spare parts kit on site the breeder can save a lot of money. The reparation that needs to be made can often be done with assistance over the phone.

Item no.	Product description	Price
50200425	Spare parts kit for Soffie all types	597,00
50200426	Spare parts kit for Soffie all types, abroad	1.360,00
50200042	Filter kit, big, incl. feeding pump Jasopels/Soffie 600/700	1.210,00
50200043	Filter kit, big, incl. feeding pump Jasopels/Soffie 950-1500	1.290,00
50200427	Filter kit, big, incl. feeding pump Jasopels 2000	1.317,00
32800040	Spare parts kit for Flething Machine T4/T5	1.205,00
32800041	Spare parts kit for Flething Machine T4/T6	1.215,00
32800046	Spare parts kit for Slicing Machine T3	800,00
32800047	Spare parts kit for Body Hook/Maxi Hook	340,00
32800048	Spare parts kit for Skinning Machine T4/T11	205,00
32800051	Spare parts kit for WRAP Machine T4	800,00
32800052	Spare parts kit for WRAP Machine T5 MaxiStretch	675,00
53200520	Spare parts kit for Pelting Robot	1.205,00

JASOPELS PELTINGROBOT XXL HELPS TO OPTIMIZE WORKFLOW AND PROVIDES BETTER SKINS

A new pelting robot gives more freedom during the pelting season and helps to optimize the quality of the skin at Hans and Claus Christensen's farm.

Thanks to his new Jasopels Pelting robot XXL Claus Christensen has moved skinning process to his own farm where he manages a pelting center together with another farmer.

– Until the last season we had a pelting center together with a colleague. We have continued this work but now equipped with a pelting robot which relieved us from having to move the bodies, explains Claus Christensen, who manages a minkfarm together with his father Hans Christensen.

Having their own pelting robot they can pick up the right skinning time and as a result, to obtain the optimal stretchability of the skin.

– After skinning we freeze the skins before they are sent to the pelting center. We don't have to carry bodies any more and because we decide about the pelting moment ourselves, we expect to get some better results, states Claus Christensen.

The right solution

Having shared a pelting center with his colleague, Claus Christensen is well acquainted with Jasopels pelting robot.

– We can see that the new model received quite a few upgrades and improvements. For example an arm which goes up, grabs the skin and takes it all the way round. Thanks to this arm, we avoid problems with big skins, he concludes.



In the past it was sometimes necessary to make an extra cycle to skin bigger males.

– We skin approximately 80 mink per hour. The cutting is performed better than before, with a nicer cut, and also the knives do not get worn out so quickly, says Claus Christensen.

Before, knives had to be changed after each 2.000 skins, now even 8.000 animals are skinned without exchange of knives.

– The robot is just right for us, as the pelting line is operated by three men and there is only 3 – 4 hours of work at our farm. Pelting robot fits a farm like ours, with 3.300 females, concludes Claus Christensen.



It is our great pleasure to present to you the Jasopels Pelting Robot XXL.

The Pelting Robot's appearance is the same but its insides have been much improved. We have taken the best features from the previous models and put them together with the market's best skinning technology from our Skinning Machine T11, so we now dare promise you that you can skin even the biggest males yourself, without any unwanted stops during the process.

The skinning process takes place by means of a more linear motion and the number of movable parts has been reduced so that

the machine is more user-friendly. We have installed a bigger display and loaded new software so your Pelting Robot XXL is ready to meet the challenges of forthcoming years – at least as far as size is concerned.

- **Improved skinning system, suitable for the largest animals**
- **Simplified operation**
- **Faster training**
- **New display with more functions**
- **Faster skinning and thus greater capacity**



TRAINING
Learn to achieve optimal quality using your Jasopels Pelting Robot XXL

Price EUR

52.570,00

Incl. conveyor belt

Technical data	
Process time	approx. 20 seconds
Electricity	3 x 400 Volt + ground/fault current switch type B
Air	600 l/min + minimum 8 bar
Dimensions	L.: 380 cm H.: 128 cm W.: 200 cm
At connection to the robot, the RCD relay must be: ac/dc - 0,3 A, type B	

SPARE PARTS FOR PELTING ROBOT



32710010
Belt, Blue, 4x295mm



53200012
Pneumatic oil



53200015
Spring feather for double cut



53200025
8-edge knife, Ø50



53200030
Contact for pneumatic knife



53200050
Scalpel knife



53200058
Tight rolls for pneumatic knife



53200063
Paw holder



53200094
Wheel for pneumatic knife



53200155
Spike chain



53200216
Head cutter together with click system



53200478
Ball bushing KB2045PP



53200486
Air engine M53N1AS-015 (L)



53200487
Air engine M53N1AS-015 (R)



53200489
NSK 6004 DDU M / double lip seal



53200520
Spare parts kit, 4 M Pelting Robot



59200093
Foot pedal with emergency stop



59200326
Insert for foot pedal



59200330
C74 element (Black) C74-RAST SU12VS

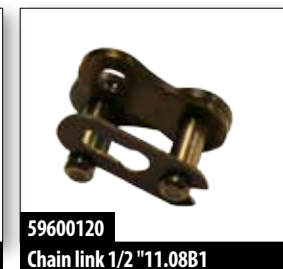

59600120
Chain link 1/2 "11.0881



51200092
Knife, round, Ø50 High Speed Steel



51200120
Knife, round, Ø80 High Speed Steel



59100284
Fitting VDMA Cyl. Ø50/63 Series 1320



53200045
Inductive sensor for cylinder

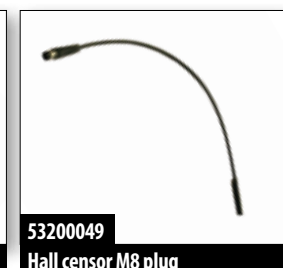

53200049
Hall sensor M8 plug



53200048
Wire for Hall 5 m with M8 plug

JASOPELS FLESHING MACHINE T6

If a skin isn't fleshed well, it will be ruined in the warehouse – The Fleshing Machine T6 is more precise, faster, cleaner and easier to use than others – says Artur Krawczyński, who takes care of the machinery at the Fortuna Agricultural and Breeding Farm. – Thanks to the T6, we process 200 skins more daily. What's more, the skins leave the machine in perfect condition.

You've only been processing your own skins for a few years. When did you decide to use Jasopels machines?

That's true, although we've been breeding for more than a decade, we've only been processing for four seasons. We've been working on Jasopels machines since the beginning. We started processing at a time when technology was already at a high level, so our first fleshing machine was a T5. This year, for the first time, we worked on the newest fleshing machine, the T6. We've also got a skin softener, a sawdust heater, and Jasopels Easy Off boards. The T6 is more efficient, faster, cleaner, and easier to use and maintain. One person can operate it, and training the operator is simple. The work is lighter. Sometimes the operators beg each other to change places, so they can work on the T6.

So the machine is cheaper to maintain. Is it also more computerised?

Compared to the previous machine, in the T6 nearly every parameter can be regulated – we can now choose more settings. For example, impellers turn at 1500 rpm, but we can alter that. Thanks to this, the skins come out of the machine in perfect condition.

What has been improved?

The distance at which the fleshing begins has been made smaller. The workers at the drying stage notice this difference most, when they cut off remnants of fat. The females this season were fleshed really well. Thanks to the new machine, we processed about 200 pieces more each day, because the whole process went smoother.



How would you sum up the whole season of work on the Jasopels T6?

We didn't have any problems with the new fleshing machine. The only thing we didn't expect was that after cleaning the beam with water, the skins sometimes come out with damp pelts. At first, we were terrified that they were greasy. When a breeder sees greasy fur, he panics instantly, because it's very difficult to get the fat out of the pelt. But there was no such problem, it was only water. After they dried, the skins were in perfect condition.



JASOPELS FLESHING MACHINE T6

ITEM NO. 32200006

Self-adjusting impellers

Jasopels has developed a system that no longer requires you to adjust the impellers after installing new ones. The new Jasopels Fleshing Machine T6 adjusts the impellers itself based on the data that have been typed in on the user-friendly touch screen. The Fleshing Machine is therefore easy to operate for new employees and gives the user a good and regular result!

No mess

The new Fleshing Machine T6 has many good features, one of which is that the mess it creates is minimal. Thanks to the new closed suction box the fat from the fleshing device does not get the Fleshing Machine dirty and at the same time it keeps the impellers quite clean.

The effect is an easier work day for you, a better working environment and, what is even more important, a better and more regular fleshing result and a greater capacity.

TRAINING
Learn to achieve optimal quality using your Jasopels Fleshing Machine T6.

New technology makes changing of impellers amazingly easy!



Impellers
page 64-65

Sharpening
of impellers
page 66

- Operates with harder impellers
- Self-adjusting impellers
- Quick changing of impellers
- Shock absorption of the fleshing engines
- Adjustable beam speed
- 4 variable fleshing zones, speeds and pressures
- Closed suction / Fleshing compartment
- Separate control cabinet
- Almost no cleaning
- Automatic travelling distance
- Possibility of presetting the speed of the fleshing engine

Price excl. suction device EUR
107.435,00

Technical data	
Electricity	3 x 400 Volt + N + PE
Air	10 l./min and 8 bar
Dimensions	L: 470 cm H: 210 cm W: 190 cm

EFFICIENCY AND QUALITY WITH THE NEW JASOPELS FLESHING MACHINE T6, EQUIPPED WITH BEST IMPELLERS ON THE MARKET

Martin Sinkjær has been able to increase skin quality in his pelting center using Jasopels Fleshing Machine T6. In the last season he produced 390,000 skins.

Martin Sinkjær operates a constantly growing pelting center that in the last season pelted mink for 29 breeders. A total of 390,000 mink went through his pelting facility, operating 24 hours per day, six days a week.

– We have used Jasopels Fleshing Machine T6 for the last four years and bought another one last season. We are very excited about this model, as it ensures high uniformity and needs very little maintenance, says Martin.

He has 62 employees working in the pelting season, and one of the key issues for him is reliability and quality.

– The new fleshing machine is better in maintaining excellent quality. And it's constructed in such a way that the moving parts such as axles, air pistons and bushings are protected from grease and dirt, Martin emphasizes.

Quality over quantity

A quick workflow in fleshing is not the most important thing for Martin Sinkjær.

– We are pelting slowly because our customers do not pay for quantity but quality. Of course I think in terms of time, but time must not be overrated in relation to what comes out the other end of the machine, he stresses.

With two shifts and four fleshing machines, many machine operators are involved in fleshing.

– It is surprisingly little we need to adjust in the machines. The most important thing is that the basic settings are in place from the start and that you adapt the speed to what works best, says Martin.

He estimates that it is possible to increase the speed, but then compromises begin as it comes to quality.

Unique impellers

As many others, Martin has discovered how easy it is to change impellers on the T6 model.

– It takes 5 minutes compared to 25 on the previous model. It's really easy to change the impellers and I would say that this is the crucial reason why I bought it, he says.

Especially the new impellers are something truly excellent.

– The new impellers are simply unique. I think that the hard inner core helps the impeller keep much more in balance throughout the fleshing process. Therefore, it is not so hard on the skins. I think we have never torn so few skins as we did last season.

– It seems to me that the impeller more cuts than presses off the fat. It is undoubtedly a great improvement, says Martin.

In my pelting facility the impellers are changed after 5,000 to 6,000 skins – which gives roughly one change a day.

– Overall, Jasopels T6 Fleshing Machine is the absolutely best investment that we have made, taking into account our production, where we flesh 24 hours per day. It gave us perceptibly higher quality and reliable operation, concludes Martin Sinkjær.



JASOPELS FLESHING MACHINE T6 – DETAIL IMAGES

Fast change of impellers

The newly-developed system in the Jasopels Fleshing Machine T6 can move the impellers out of the suction box using compressed air. This improves working conditions while changing the impellers and makes things much easier.

After the impellers have been installed, they are moved to the right position via the display and then they are automatically adjusted. An experienced employee can do all this in just 5-7 minutes.

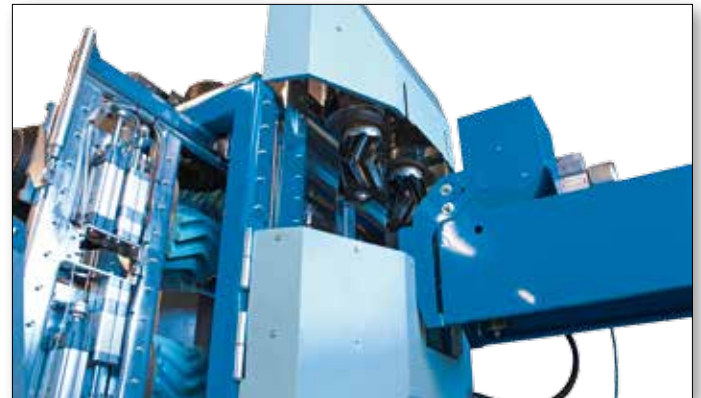

Technical data	
Electricity	3 x 400 Volt + N + PE
Air	10 l/min and 8 bar
Dimensions	L: 470 cm H: 210 cm W: 190 cm
Dimensions / cabinet	L: 60 cm H: 170 cm W: 40 cm
Connection	CEE 32 A plug AC/DC relay + Air + Water
KW peak	15,88

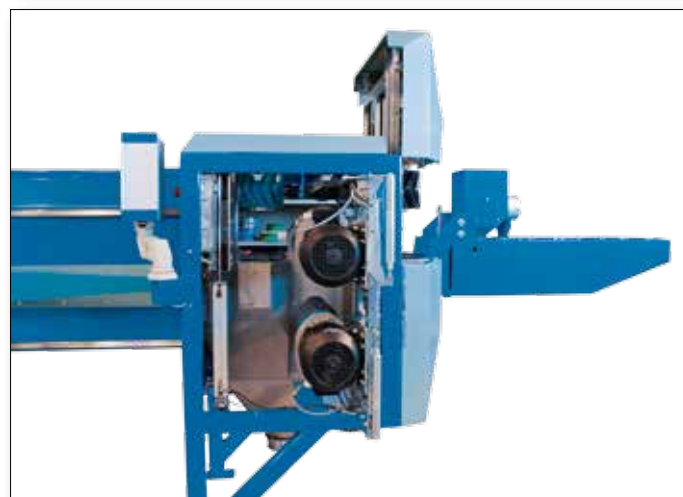
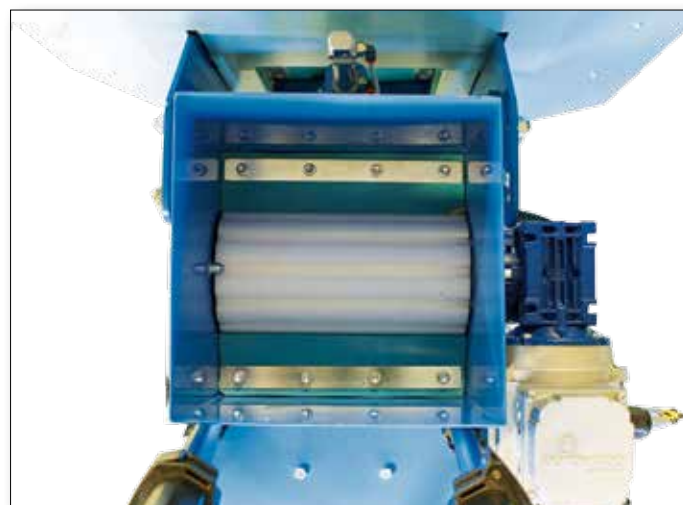



Impellers
page 64-65



Sharpening
of impellers
page 66

It comes as no surprise that for decades the Jasopels Fleshing Machine XL has been praised as the best fleshing machine on the market. It performs a solid piece of fleshing work and it is quick, cheap to run and very reliable.

– This is why we have made it even better!

The big touch screen gives the operator quick overview and provides a chance to switch between the machine's operating modes in an easy and manageable way. This allows you to achieve a more regular fleshing result even if your skin types are mixed!

Active Per4mance® is a system developed by Jasopels that makes it possible for you to change the beam speed and the impeller pressure of 4 independent zones. This allows you to adjust the machine precisely to your skins.

All impellers have been equipped with shock absorbers. In practice this means that the impellers stay on the skin, which results in a significantly better fleshing. At the same time the machine is a lot gentler when fleshing damaged skins!

- **Better fleshing**
- **Less risk of fat extraction**
- **Increased income**

Price excl. suction device EUR

53.380,00

Technical data	
Electricity	3 x 400 Volt + N+PE.
Air	10 l. / min. and 8 bar.
Dimensions:	L.: 440 cm H.: 190 cm W.: 100 cm
KW peak	13,68
Connection	CEE 32 A plug + Air

JASOPELS ROTATING FLESHING MACHINE 4000 XXL

ITEM NO. 33100003

Jasopels rotating fleshing machine 4000 XXL with 2 impellers.

As one of the best, most reliable rotating machines on the market, the Jasopels Fleshing Machine has the following features:

- **Double Jasopels rotary impellers fitted with XXL beams to ensure that even large skins are perfectly fleshed**
- **Touch screen and frequency controller that facilitates operation and changing the settings**



Price EUR
20.935,00

Technical data

Dimensions:	L.: 238 cm. H.: 184 cm. W.: 125 cm
Air	51./min.
Electricity	3 x 400 Volt + N + PE
Connection	CEE 16 A plug + Air



Item no. Product description Price

33900014	1 Impeller 100 mm, black	*
33900013	2 Impeller 100 mm, hard, yellow	*
33900015	3 Impeller 100 mm, gray	*
33900006	4 Tail clamp for the machine	*
33900021	5 Paw hook for Rotomax and Jasopels Rotary Fleshing Machine 4000 XXL	*
33900009	6 Fishing machine cord	*
33300002	7 Vacuum suction device, 2BH1600-7AH16,3 kW, for a single rotating fleshing machine	1.720,00

JASOPELS FAT PUMP

ITEM NO. 32200024

Pumps the fat directly to an external container.

The fat is pumped to the container through a hose.

The machine can pump the fat up to 20 meter horizontally – it all depends on the bend.

Price EUR
7.420,00

Technical data

Electricity	3 x 400 Volt + N+PE, 2,2 kW
Connection	CEE 16
Dimensions	L.: 150 cm H.: 200 cm W.: 90 cm
KW peak	7,7

Item no.	Product description	Price
50100088	BoWex M 38 nylon ratchet	*
52600068	Muffler - Transfer Ø160x990	*
32800036	Reconstruction for fat transport. to fat pump	*



JASOPELS LEATHER SIDE DRUM

ITEM NO. 32200036

- *Tumbles and cleans the skins twice*
- *Better tumbling*
- *Larger diameter*
- *No belt drive*
- *Safe construction*



Price EUR
6.745,00

Technical data

Dimensions:	L: 240 cm H: 130 cm W:110 cm Ø 100 cm Drum Diameter
Electricity	3 x 400 Volt + PE
KW peak	0,55
Connection	CEE 16 A plug

SPARE PARTS FOR FLESHING MACHINE

Item no.	Product description	Price
32720017	1 Rubber for Sawdust Automat 02-1220	
32720020	2 Rubber for Sawdust Automat 02-1223	
32720023	3 Beam scraper, rubber, EKSTRA short 50 x 75 mm	
32720021	3 Beam scraper, rubber, short 50 x 90 mm	
32720022	3 Beam scraper, rubber, long 50 x 110 mm	
32720010	4 Rubber for beam 55x 130 mm - vertical	
32720012	5 Rubber for beam 65 x 200 mm - horizontal	
32720011	5 Rubber for beam 75 x 200 mm - horizontal	
32720142	6 Rubber for scraper 40 x 80 mm - yellow	
32720026	7 Rubber for scraper 40 x 180 mm - green	
51100202	8 Rubber for fat suction, without core (2xT5)	
51100196	9 Rubber for fat suction, without core (2xT5)/(4xT6)	
51100081	10 Rubber for scraper, beam washer, short 30 mm, core 40 x 132 mm T5 - black	
51100077	11 Rubber for scraper, beam washer, long 30 mm, core 40 x 180 mm T5 - black	
32720145	12 Rubber for beam washer, short, with grinded core 40 x 130 mm T6 - turquoise	
32720143	13 Rubber for beam washer, long, with grinded core 40 x 180 mm T6 - turquoise	
32800040	14 Spare parts kit for Fleshing Machine	
51100086	15 Rubber block for Skin Remover	
51100144	16 Spring 95 mm for skin scraper	
51100143	16 Spring 105 mm for skin scraper	
51100215	17 Fleshing motor 3 KW set	
51100256	18 Fitting for chain on sled galvanized (for axles)	
51100255	19 Chain bracket	
51100257	20 Bracket for chain for slide, galvanized (for skin remover)	
51100278	21 Beam T4/T5 set	
51100328	21 Beam T6 set	
51100283	22 Shock absorber for Fleshing Machine	
52900078	23 Water nozzle for beam washer	
52900079	24 Air nozzle for beam washer	
59100104	25 Magnet coil 240V/50Hz for M pilot MB25	
59100130	26 Valve 3/2 1/8 air/spring	
59100140	27 Valve 5/2 1/8 air/spring	
59100228	28 Cylinder VDMA Ø 40 x 050 u. Br/Ma	
59200287	29 Inductive switch pnp shielded no. M18	
51100358	30 Nose holder for beam T5	
51100335	31 Nose plate stainless for beam T6	
51100487	31 Plate, black for nose plate	

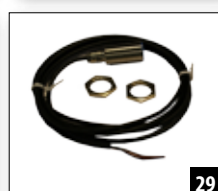
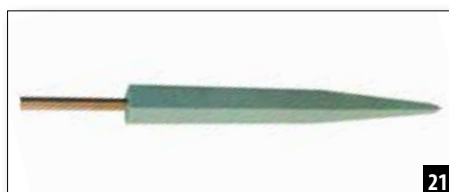
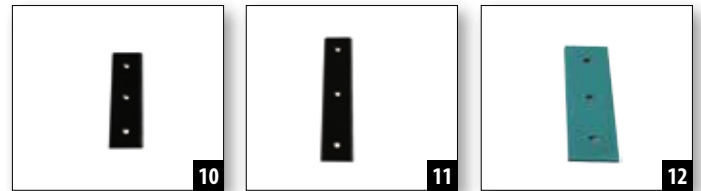









A new series of Jasopels impellers is on the market. Thanks to the brand new wave pattern that we call the MotionWave, Jasopels has once again succeeded in taking effective fleshing to the next level. The new impellers have deeper grooves that can carry more fat, helped along the way by the moving cutting motion.

On top of that the new impellers are sharpened in a brand new way, thanks to which they have a considerably sharper profile than other known products. The new impellers come in various versions – with 7, 8, 9 or 11 teeth. Of course, we still produce the 8-tooth impeller with a traditional pattern and deeper grooves for easier fat removal.

Shore	Hardness	Recommended maximum pressure	Color		Item no.	Tooth	Hard Core	Type	Advice for use	Price EUR
70	Very soft	Max. 1,3 bar	Black		32720038	8 tooth		Straight impeller	Preferable for very delicate females	94,50
					32720097	8 tooth		Waved impeller		94,50
75-78	Soft	Max. 1,5 bar	Yellow		32720045	8 tooth		Straight impeller	For delicate females	94,50
					32720104	8 tooth		Waved impeller		94,50
					32720107	9 tooth		Waved impeller / front legs		135,00
					32720058	11 tooth		Waved impeller / T6		135,00
80-82	Ordinary (Not soft / Not hard)	Max. 2,0 bar	Blue		32720044	7 tooth		Waved impeller / front legs	For delicate males and normal females	94,50
					32720101	8 tooth		Straight impeller		94,50
					32720100	8 tooth		Waved impeller		94,50
					32720059	11 tooth		Waved impeller / T6		135,00
84-85	Ordinary + harder than ordinary	Max. 2,5 bar	Turquoise		32720046	7 tooth		Waved impeller / Front legs	For normal males and tough females	94,50
					32720103	8 tooth		Straight impeller		94,50
					32720099	8 tooth		Waved impeller		94,50
					32720060	11 tooth		Waved impellers / T6		For normal males and tough females 135,00

JASOPELS IMPELLERS



Shore	Hardness	Recomended maximum pressure	Color		Item no.	Tooth	Hard Core	Type	Advice for use	Price EUR
88	Hard	Max. 3,0 bar	White / clear		32720096	8 tooth		Waved impeller	For tough males that are difficult to flesh	94,50
					32720111	8 tooth	Yes	Waved impeller		94,50
					32720128	11 tooth	Yes	Waved impeller / T6		135,00
					32720061	11 tooth		Waved impeller / T6		135,00
95	Very hard	Max. 3,5 bar	Red		32720112	8 tooth	Yes	Waved impeller	Used on the back of very tough males	94,50
					32720129	11 tooth	Yes	Waved impeller / T6		135,00
100	Real hard	3,5 bar	Pink		32720113	8 tooth	Yes	Waved impeller	For males who cannot be fleshed with the red impeller	94,50
					32720054	11 tooth	Yes	Waved impeller / T6		135,00





At Jasopels we can also sharpen your impellers.

As the only market provider we carry out 3 stages of diamond grinding (coarse, medium and ultrafine) Before we grind, we take a 3D measurement of the impeller. This is a guarantee of a perfect finish and no uneven surfaces. We grind in match, so the diameters remain the same.

We grind impellers from all manufacturers. We guarantee that impellers are equally grinded. All new Jasopels impellers are surely grinded the same way.

Contact us to get a price.

Tel. 98 42 05 66 or info@jasopels.dk

ATTENTION: Remember to clean the impellers before shipping. Not cleaned rolls are rejected and returned untreated because of infection risk.



JASOPELS FLESHING MACHINE T6 AND IMPELLERS – STRIVING FOR PERFECTION

At Kloster Mink, despite the famous jutlandic moderation, everyone is quite excited about Jasopels Fleshing Machine T6 and impellers.

Bo Kloster got a new Jasopels fleshing machine T6 for the new season, mainly to be able to flesh both females and males with the same machine.

– We didn't actually buy a new fleshing machine because we needed to improve the fleshing process, yet, my impression is that the new impellers are more gentle for the skin, when e.g. there are defects on the skin, large ears, or even just a tiny hole, says Bo Kloster.

At Kloster Mink everyone is extremely satisfied with the effects the machine had on approx. 50.000 skins that were fleshed with it in the past season.

– If you're planning to purchase a new fleshing machine, you almost have to try this one. It is a complete, mature product – I cannot think of any areas where it should be improved or amended, highlights Bo Kloster.

One of the machine's main advantages is the facility to make adjustments via touch screen.

– I control the settings personally and therefore virtually anyone can operate the fleshing machine, says Bo Kloster.

Gentle and effective impellers

Bo Kloster decided to use some relatively hard impellers for fleshing.

– We probably use harder impellers than others, but in return we use a lower pressure and that works very well for us, he says.

When it comes to cleaning and change of impellers, the machine is very user-friendly.

– It is easy to change impellers and what is important, the machine does not get dirty during the exchange. In the past you had to do the cleaning before you changed impellers and still you were all covered in grease after the work was done, recalls Bo Kloster.

He estimates that it does not take more than five minutes to change impellers.

– Also, we don't have to adjust impellers any more. This is done by the machine. We change the impellers after approx. 6.000 skins and once a day we switch from male to female, says Bo Kloster.





JASOPELS SKIN WASHER

Are your skins dirty? Jasopels has the solution for that! We have a skin washer that can wash your skins gently without compromising the quality.

The skin washer can be purchased with a capacity that matches your needs.

Item no.	Product description	Capacity	No. of skins	Price
32300021	Jasopels Skin washer LW9	9 kilo	30	3.410,00
32300022	Jasopels Skin washer LW12	12 kilo	40	4.095,00
32300023	Jasopels Skin washer LW15	15 kilo	50	4.720,00
32300024	Jasopels Skin washer LW20	20 kilo	60	5.630,00
32300025	Jasopels Skin washer LW27	27 kilo	80	6.335,00
32300026	Jasopels Skin washer LW32	32 kilo	90	7.500,00
32300034	Jasopels Skin washer LW40	40 kilo	110	10.115,00
32300035	Jasopels Skin washer LW60	60 kilo	160	12.270,00
A plinth, if required, must be purchased separately				
L.: 91,50 cm H.: 141 cm W.: 89 cm				



BETTER FINISH WITH THE JASOPELS SKIN WASHER

With the Jasopels Skin Washer Kim Drejer gets better skin cleaning than previously

After the first season of using the Jasopels Skin Washer, Kim Drejer from Drejer Mink comes to a clear conclusion.

– Cleaning takes as much time as before, but the handling is much easier and we clearly get better results, he says.

Before he invested in the Jasopels Skin Washer, the skins had been cleaned with sawdust.

– Surely you can save money with the Jasopels Skins Washer, but it also takes time because the skin must be turned and drummed again before pinning, says Kim Drejer.

When the spring season comes, all male skins will be washed, contrary to the previous system, when whole minks were washed.

Wool washing powder works best

Kim Drejer experimented with different types of detergents to wash the skins, he even tried to use only water.

– We cannot do without soap, and we have also found out that the wool washing powder works best for us. It ensures that the skins remain resilient, explains Kim Drejer.

He estimates that skin cleaning required more physical work in the past, and that now he even saves some sacks of sawdust.

– With the Jasopels Skin Washer soap is now completely washed out of the skins. It did not happen before, where we had a bluish tint on the white skins.

– If you take into consideration all aspects of purchasing the machine, I think the money is earned back home, concludes Kim Drejer.



- A new, improved sawdust product
- Available in two types: 50 mix and 60 fine in 20 kg bags
- Delivered on pallets with 36 bags each
- Can also be purchased in big bags -- 2 x 400 kg or 1 x 800 kg

YOU CAN SAVE MONEY
 – purchase with delivery in spring 2016 and get substantial discount.



Item no.	Product description	Price
30100003	Jasopels sawdust, type 50 mix	*
30100004	Jasopels sawdust, type 60 fine	*

SAWDUST IN BIG BAGS – NO MESS OR HASSLE

Jasopels Mix comes in big bags, which Niels Vesterholm finds very handy. He also appreciates the absorption of the sawdust and its right texture for skin processing

Niels Vesterholm has run his Ølholm Mink plant since 1984 and for more than 20 years has had his own pelting facility. Over the years he has developed a very effective way to use sawdust.

– Since 2003, when we established our current fleshing plant, we have been getting sawdust in big, 900 kg bags. We drive the bag with a truck over a hopper and open it up, so that the bag empties itself during the day, Niels Vesterholm says.

He pelts 20,000 of his own mink in the season and further 20,000 mink for his local colleagues.

– It suits our way of production that we only need to change the bag once a day when we process 1,200 skins for drying together with the mink for fleshing, Niels notes.

Closed sawdust system

In the fleshing plant there is enough space and there is an iron bar under the roof where the bag with sawdust can be attached, so it can be driven back and forth.

– The sawdust goes through a heater that heats it up to 25-27 degrees. Later it goes to a silo for the skins, which are drummed on the fur side.

– Then the sawdust goes to the leather side drum and as the drum throws out the dust, it goes to the silo which we use with the fleshing machine, Vesterholm explains.

When the sawdust has been used by fleshing machine it is swept down to an outlet in the floor, returns to the empty bags and ends up as fuel.



Good absorbency and structure

In recent years, Niels Vesterholm has been using the same type of sawdust.

– We only use Jasopels Mix sawdust. It has a very good absorbency, as well as an excellent, uniform structure. It is very rare that there are any variations in the bag that I receive, he points out.

Some years ago he tried using sawdust from another supplier.

– Although we have a fairly closed system, there was up to two centimetres of dust all over the place, he recalls.

What can negatively affect the efficiency of sawdust is wrong temperature.

– The temperature is very important. If we heat the sawdust ineffectively, you can immediately see it on the quality of the skins, Niels Vesterholm remarks.

HIGHER PERFORMANCE AND EASE OF OPERATION WITH JASOPELS WRAP MACHINE T5 MAXI STRETCH

With WRAP Machine T5 Maxi Stretch and Jasopels boards, pinning is significantly easier and the quality and skin sizes have both increased.

Father and son, Bjarne and Michael Mikkelsen, run a mink farm Kær I/S with 10,000 females, where they above all focus on animals' welfare and quality of the product.

In the previous season they bought a Jasopels WRAP Machine T5 Maxi Stretch for their pelting centre and recently they bought another one.

– The fact that we bought this machine again last season shows perhaps best of all how happy we are with it, says Bjarne Mikkelsen.

The skinning is done by a colleague who also does the fleshing of the males. The remaining pelting work is done back on the farm.

– The WRAP Machine pulls the skins well and the boards can keep the size of the skins until they are dry. We no longer have the problem of overstretched skins since we changed to the new machine, Michael Mikkelsen emphasizes.

The new Jasopels boards make it much easier to take the skins off.

– It has almost become a female job. It was certainly not like that before – it was really hard work, Bjarne Mikkelsen recalls.

Good support for the machine and boards

During a working day of eight hours about 1,600 skins will be put on boards with the use of two machines.

– The most important thing for us is the quality of work, and there must be an awareness of that among our employees. We do not attempt to do the work as fast as possible – instead we focus on



quality. This is where we earn most money and get greatest satisfaction from work, Bjarne Mikkelsen emphasizes.

He estimates that the WRAP is doing a good job, and he appreciates the statistics function of the machine.

– When we take the numbers from the machine and compare them with sales statistics which we get from Copenhagen, they are exactly the same – before, things were different, says Bjarne Mikkelsen.

Despite his Jutland modesty, he admits he is satisfied with the support for the new machines.

– We must give praise to Jasopels. It's great to get a product with good service which is available immediately when you need it, says Bjarne Mikkelsen.



JASOPELS WRAP MACHINE T5 MAXI STRETCH

Optimal stretching of skins allows the breeder to obtain a larger pelt, automatically raising its value. – It's often a matter of a centimetre or two – stresses Artur Andrzejewski, manager of a mink farm owned by Bono Fur Farm. And it's hard not to agree with him. Bono Fur Farm's products are top-shelf, and as the only farm in Poland to do so, it sells genetic material to Denmark.

Judging by the number of trophies in the office, Bono Fur Farm has been in business for some time. How did it all start?

We started our first breeding facility in 2004. It was an idea cooked up by Mariusz Konieczny and Robert Mieleńczuk. With time, the next facilities came along. Now we've got four farms in total in different locations around the Western Pomeranian district.

What's the secret of your success?

Since the beginning, we've focused on quality. When Mariusz and Robert were setting up their first facility, they drew heavily on the experience of American and Danish breeders. For this reason and others, and because they set the bar so high for themselves, the level of fur production in the entire country was raised. At present, Poland is among the international leaders in the production of high-quality mink pelts, and Bono Fur Farm is the only manufacturer in Poland that sends genetic material to Denmark. Usually, things go the other way.

Have you been working on Jasopels machines for long?

We got involved with Jasopels about three years ago. At that time, we made our first test-runs on the latest WRAP stretching machines at the time. The issue came up again when we started looking at modernisation.

Throughout last season you used the latest Jasopels WRAP Maxi Stretch machine. What are your impressions?

The skins are stretched perfectly. The tension is definitely better than on our previous machines. There's a huge difference.

Buying a new stretching machine is a big expense. When will your investment return?

If the skin is perfectly stretched, we can obtain more size, which automatically begins to pay off the investment. It's often a matter of a centimetre or two. If the machine is capable of stretching the skin to the limit of a size class, but not of crossing into the next class, there's no point. With the number of skins that we process, this starts to add up quickly.

Are there losses with the WRAP Maxi Stretch?

Regardless of the machine, there will always be some losses. Every material, in this case skin, has its limits. The amount of damage done is often a matter of greediness or lack of experience on the part of the operator, but with the WRAP Maxi Stretch there are significantly fewer losses than with other machines.



JASOPELS WRAP MACHINE T5 MAXI STRETCH

ITEM NO. 32300004

TRAINING

Learn to achieve optimal quality using your Jasopels WRAP Machine T5 Maxi Stretch

With the latest programming update, the stamp-function has been replaced by a more gentle, uniform stretch to ensure that the skin reaches its maximum size without traces of jaw-marks, stretch lines, or hair loss. The skin is stretched from nose to tail in a uniform and efficient stretch.

Ideal results are achieved when used together with the new Easy Off XL Board, as the board contains a magnetic chip that the stretching machine can recognize and thereby automatically makes sure that the stretched skin is entered correctly into the statistics.

Dynamic Force ensures optimal skin

With Dynamic Force®, you are ensured that your skins are stretched optimally, as the system adjusts to each individual skin during the stretching.

In short, the way the system works is that the Jasopels WRAP Machine T5 Maxi Stretch measures the skin, and the machine's force is then adjusted accordingly. This means that a skin measuring size 0 before stretching is not exposed to as much force during stretching as a skin measuring size 2 x 0, because the largest skins can handle the application of greater force.

Stretch'n'release function

When a skin does not stretch to the next size, there is no reason to keep it stretched to its outermost limit. In these cases, the Jasopels WRAP Machine T5 Maxi Stretch can automatically relax the force a bit, so you are given an optimized relationship between size and quality.

Jasopels WRAP Machine T5 Maxi Stretch has the lowest operational cost on the market!

- **Quick changes between skin types via 8 different programs**
- **Quick, easy, and economical**
- **Soft function for damaged or vulnerable skins**
- **Adjusts force and tempo to each individual skin**
- **As the only pinning machine on the market, our pinning machine distinguishes between XL boards and standard boards**



Price EUR

32.420,00

NEW

Technical data	
Air	40 l/min and minimum 8 bar
Electricity	230 Volt + PE
Relay	Super resistant HPFI
Dimensions	L: 80 cm H: 125 cm.W: 80 cm
KW peak	1,5
Connection	230 V plug - AC/DC relay + Air

Item no.	Product description	quantity per box
32730003	Wrap foil 50 mm black	32 rolls
32730004	Wrap foil 50 mm yellow	32 rolls
32730005	Wrap foil 50 mm green	32 rolls
32730006	Wrap foil 50 mm white	32 rolls
32730007	Wrap foil 50 mm red	32 rolls
32730008	Wrap foil 50 mm blue	32 rolls

Now wrap foil is available in 6 different colours. This can make it easier to track skins from individual farmers if several wrap machines are in use.



NEW JASOPELS BOARDS CAROUSEL OPTIMIZES PINNING AND REDUCES MAN-HOURS

Sydvestjysk Pelting Centre in last season produced 760.000 skins with a focus on optimizing costs, time and quality.

The Centre increased its number of machines and added more focus on workflow and quality.

– Above all, we have increased the number of skins. In previous seasons we skinned around 25.000 mink a day, this year we went up to about 40.000.

– Before all the final processes such as stretching, drying and packaging, we now produce between 10.000 and 10.600 a day. Last year we produced 5.000-5.600 skins a day, says Christian Winther, director of Sydvestjysk Pelting Centre.

The number of skins processed last season was 580.000. This figure rose to 760.000 skins this year.

– We have hoped to make between 800.000 and 900.000 skins, but more mink than expected were sold for breeding this season, Christian Winther explains.

Carousel in the pinningboard room

In the skinning area we went from 7 to 11 skinning lines, once Jasopels became our machine supplier. Along with the increased volume of pelts in the fur season we also experienced a need for significantly more employees.

– It's been really hectic. We have gone from 130 to 180 employees, half of whom are new. Part of the increased number of skins is handled by the employees working in two shifts, so now we use our machines more intensively, Christian Winther explains.

One of the places that has changed most is the pinning room, which has really changed a lot.

– We have maintained the number of wrap machines there, but together with Jasopels we have built a carousel system, just using the conveyors. The boards and the skins are at all times ready for the operator of the wrap machine.

– It has both increased the flow and saved the work of some employees, emphasizes Christian Winther, who has also increased the number of boards and trolleys to accommodate the increased flow of skins.

Optimisation and quality assurance

With 180 employees who to varying degrees are familiar with working in a pelting centre, Sydvestjysk Pelting Centre has maintained all its senior employees who train the new ones and ensure quality.

– The quality has generally progressed well. Besides the work of our employees, we owe it to the optimized part of our fleshing. Just this area has given a boost to the number of skins later in the process, Christian Winther highlights.

Also in the further parts of the process more quality has been achieved.

– We have also optimized the workflow by the leather side drum after fleshing, so there is enough sawdust after five minutes' tumbling followed by a seven minutes' tumbling with leather cleaner. Overall, we see an improvement in our quality compared with the previous season, Christian Winther emphasizes.



JASOPELS MAXI TROLLEY

ITEM NO. 34500004

- MAXI drying box for up to 200 boards
- Rotating wheels in each corner
- Can be supplied with blowers in the drying box
- Can be connected to an existing drying installation
- Adapted to automatic skin removal
- Easy to operate



Technical data

Electricity	230 Volt 1P + n+PE
Connection	CEE
Dimensions	L: 195 cm H.: 100 cm W.: 85 cm
KW peak	0,25

With blower and timer, price EUR **1.485,00**

SPARE PARTS FOR JASOPELS WRAP MACHINE

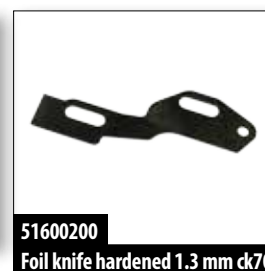

JASOPELS EASY OFF BOARDS

If you're planning to do your own processing, you need the right tools, ones which are solid, dependable, and will last for years. That's exactly what Jasopels Easy Off Boards are – says Artur Andrzejewski, manager of a mink farm owned by Bono Fur Farm. He feels that Jasopels boards, made of hard-wearing materials, and with adjustable width, are a revolutionary product without compare.

Since 2009 you've been the manager of a mink farm owned by Bono Fur Farm. What has changed in mink breeding?

The production process has changed diametrically. Manufacturers of pelting machines, such as Jasopels, are introducing changes and improvements each year. Easy Off boards were a revolutionary product. When they worked out well for us, we decided to have a look at other products from Jasopels. At the beginning of the 2015 season, we bought a Jasopels WRAP Machine, a stretching solution, and we're currently discussing feeding machines.

What is so revolutionary in Easy Off boards?

Well, as the name itself suggests, they are very easy to use and it's easy to remove skins from them.

What kind of production figures are we talking about?

I can safely say that we process about 30,000 pelts a week.

So you really need dependable tools?

Absolutely! Ones that we can rely on. Of course nothing is 100% error-free, but that's true in every branch of industry. All the other boards that are now available on the market have adjustable width. But Jasopels Easy Off boards are made of better material, and right now they're unbeatable.

Breeders often speak highly of Jasopels' fast and high-quality after-sales service. What's your experience?

The service is one of the major advantages of Jasopels. As I mentioned, there's no such thing as an error-free machine, but the service from Jasopels is very fast and professional. You can see immediately that their machines are built by breeders, for breeders. They are designed by people who know the business, who have experi-

ence in the industry and know what the strengths and weaknesses of a given machine are.

Are there any weaknesses of Easy Off boards?

They're definitely not the cheapest solution out there. They make production easier, but you have to be prepared for a serious expense. They're also slightly heavier, which could be important during pinning. Our workers have pointed that out to us. Even so, thanks to their Easy Off technology, working with them is still easier, and our investment in Jasopels solutions has paid off.

Have you already replaced all of your boards with Easy Off?

Three quarters of all the boards are now Easy Off from Jasopels. Obviously, with time, we'll be buying more.

The next stage in the development of these boards is Easy Off XL, which eliminate the problem of tails shutting trolley holes. Do you also experience this problem?

If the trolley is full, there's no possibility for the tails to jam the holes. Unless the boards are too short and the skins are too long. Then it would really be a good idea to invest in Easy Off XL boards. We're thinking about it now.

You replaced the boards, but the old trolleys stayed?

That's right, we still don't have Jasopels' trolleys. All the boards of the previous generation are compatible with any trolley which can accept plastic boards. I've heard that one of the big manufacturers is working on a new system which will require the customer to buy a complete set. That's strictly a marketing ploy, which in the current market situation is shooting yourself in the foot. A lot of changes are necessary, and everybody wants to save money – that's what the Jasopels system guarantees.

Bono Fur Farm has invested a lot in the boards.

Yes, but it's an investment which produces substantial savings. If you want to do your own processing, you need the right tools, ones which are solid, dependable, and will last for years. That's exactly what Jasopels Easy Off Boards are.



**LOOSEN THE SKINS
FAST AND EASY**

EASY OFF BOARDS

The new, successful Easy Off Board is produced in five different types: two regular for male and female, and two XL that are 12 cm longer and a US board. Easy Off Board is the most expanding board on the market and ensures that the previously labor-intensive task of loosening the skins has become quick and easy.

The board's shape with strategically placed barbs ensures that the skins are fixed effectively and maintain their length. The air ducts simultaneously ensure that the skins dry evenly and effectively.

- **Simple construction - robust, durable, and easy to use.**
- **10 mm expansion**
- **New XL board + 2 sizes compared to traditional board (12 cm)**
- **Contains magnetic chip that Jasopels WRAP Machine T5 Maxi Stretch can read**
- **Easy Off Board is suitable for all standard systems**

Item no.	Product description	Price
30200010	Jasopels female board, Easy Off Board XL Length without foot 113.5 cm	16,25
30200008	Jasopels female board, Easy Off Board Length without foot 101.5 cm	10,68
30200009	Jasopels male board, Easy Off Board XL Length without foot 132 cm	20,30
30200007	Jasopels male board, Easy Off Board Length without foot 120 cm	11,35
30200015	Jasopels male board, Easy Off Board XL - US Length without foot, 126 cm	95,00

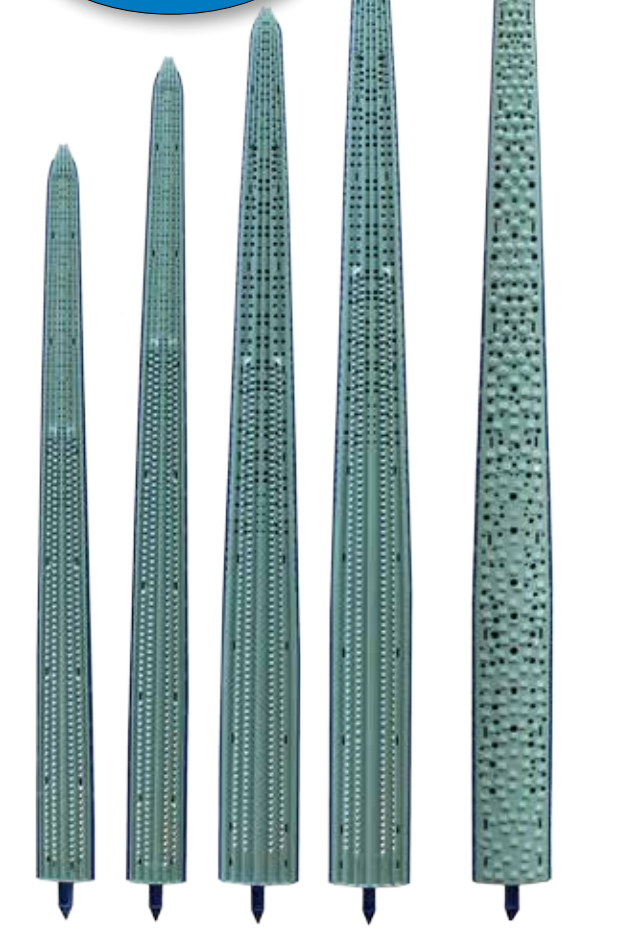

Female Female XL Male Male XL Male US Board

SLEEVES

Super quality paper. Individual solutions with larger orders.

The Jasopels sleeves are available in several lengths in great quality, which makes it easy to find a sleeve that suits your needs.

Item no.	Product description	Price
30300012	1 Sleeve Jasopels female 76 cm./ pack of 500 - US	*
30300010	2 Sleeve Jasopels female 81 cm. / pack of 500	*
30300011	3 Sleeve Jasopels, female 86 cm, pack of 500	*
30300013	4 Sleeve Jasopels, female 95 cm, pack of 500 Fits Jasopels female stretch board XL	*
30300003	5 Sleeve Jasopels, male 95 cm. / pack of 500	*
30300004	6 Sleeve Jasopels, male 100 cm, pack of 500	*
30300005	6 Sleeve Jasopels, male 100 cm pack of 500 Ekstra strong quality	*
30300002	7 Sleeve Jasoepels, male 95 cm./ pack of 500 - US	*
30300032	8 Sleeve Jasopels, male 106 cm./ pack of 500 - US	*
30300006	9 Sleeve Jasopels, male 112 cm, pack of 500 Fits Jasopels male stretch board XL	*

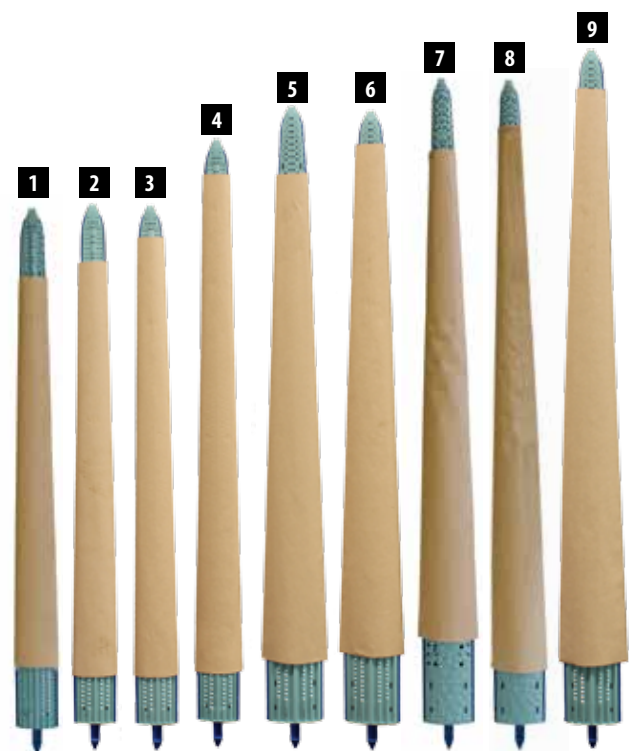

JASOPELS SKIN CLEANING AUTOMAT T5

If you want to have really tip-top skins and sell them at a better price, it is worth investing in the newest Jasopels Skin Cleaning Automat T5. All the more so because buyers pay attention to every detail during an auction. – A skin that comes out of T5 is completely different to the touch – stresses Jarosław Jasiński from Krzysztof Jasiński's Fur-bearing Animal Farm.



Is a Skin Cleaning Automat an unnecessary luxury or an essential processing tool for mink breeders?

The Skin Cleaning Automat is just as essential as every other processing tool, because it affects the final outcome, namely, the quality of the skin and its aesthetics. Some breeders think that they can comb the skins without using the proper machines, but I wouldn't recommend that. Every machine plays its part in the process; when we leave something out, the result can be seen in the prices we get at auction.

How long have you been using Jasopels machines?

We had our first taste of Jasopels machines five years ago, when we modernised the Pelting plant. The first item that we bought was a Jasopels WRAP machine. Later, we added boards, a body drum, and a T5 skincleaning machine.

In what way does the T5 save you time?

The Skin Cleaning Automat T5 carries out two processes at once, that is, it cleans and softens. Inside the machine there is a chain which runs in a circle. A clamp is mounted on it to which we attach skins, so that they are pulled through the softener and the cleaner. The T5 has two clamps like this, so the machine works twice as fast and there is no dead space. Two people are needed to operate it; one hangs the skins and the other retrieves them. The result is that

we do twice as many skins, which come out better cleaned and leave less sawdust in the box.

What is the softening for?

The skin is completely different to the touch. It isn't hard, it doesn't rustle, it becomes more elastic. When it's put up for sorting at the auction, it doesn't „crumble“.

The T5 also lets you get rid of excess sawdust?

Yes, it involves a blowing operation inside the machine. Thanks to that, we don't get negative comments during grading, that we've left too much sawdust on. A skin like that just looks better at auction.

Is the machine worth the price?

It's not such a big cost if you want to have really tip-top skins and sell them at a better price. The quality of work and price at auction are incomparably higher with the Jasopels T5 than without it.



JASOPELS SKIN CLEANING AUTOMAT T5

ITEM NO. 32500001



32300020
Skintray

Price EUR

20.260,00

Excl. suction device, cyclone and installation

The Cleaning Automat cleans the skins, softens them and makes them ready for delivery. The wool and hair are cleaned and get a "lift".

The remaining sawdust is loosened and removed from the skin. The blowing system then blows air inside the skin so that the leftover sawdust and dust is removed, all in one complete cycle.

With its high capacity, this machine is a real time saver and skin improver. The Skin Cleaning Automat gives the skin the optimal look.

The Skin Cleaning Automat T5 is 20 cm bigger. There are now 2 skin holders instead of 1, which increases the speed.

A suction unit that removes sawdust and dust directly to the container needs to be installed.

Item no.	Product description	Price
52500016	Kongskilde suction fan 4,0 kW, 400 vac, 50 Hz	1.345,00
52500018	Kongskilde suction fan 5,5 kW, 400 vac, 50 Hz	1.879,00
32300018	Pipe set and Kongskilde suction fan 4,0 kW	2.710,00
32300019	Pipe set, cyclone and Kongskilde suction fan 4,0 kW	3.365,00

Technical data	
Electricity	3 x 400 Volt + N + PE
Air	268 l/min and 8 bar
Dimensions	L.: 200 cm H.: 160 cm W.: 90 cm
KW peak	6,4
Connection	CEE 16 A plug + Air



BETTER FINAL TOUCH AND SAVED TIME

A new Jasopels Skin Cleaning Automat T5 brought very good final results and helped to find savings in working hours at Ove Jensen Tvis Pelsdyrfarm ApS

Jan Albertsen from Ove Jensen Tvis Pelsdyrfarm ApS near Holstebro has been searching for many years for an opportunity to invest in a skin cleaning automat which could raise the quality of the skin.

– I have kept an eye on Jasopels skin cleaning automat T5 for many years, during exhibitions for example. I have also seen the results achieved by my colleagues. Before the beginning of last season they convinced me that this machine is the right way to go, he says.

Before that two employees worked with a soft brush and a softener.

– Skin cleaning automat surely does a better job than the devices we used to have. It aerates skins and raises the fur which afterwards is unbelievably soft, states Jan Albertsen.

In the past season ca. 70.000 animals were skinned at Ove Jensen Tvis Pelsdyrfarm, the majority of which came from their own farm.

Greater uniformity

Apart from the improved quality of the skin, working with the automat is much more effective.

– With skin cleaning automat T5 we save one job in the high season, as now it takes one person to handle the job, whereas before we needed two men for that, says Jan Albertsen.

In his assessment the machine works in such a way that the outcome is more uniform.

– Also, the skins are cleared of sawdust and generally very clean when they go out of the automat, says Jan Albertsen.

He has been preparing the skins for exhibitions for many years and he is sure that the skin cleaning automat will raise the quality even more.

– When we prepare the skins for an exhibition, we comb them first and then put them to the skin cleaner. And even the worst skins, the flat ones e.g. can be lifted considerably, when they are run through the automat, says Jan Albertsen.



JASOPELS Q-VEX CLIMA

ITEM NO. 34100002

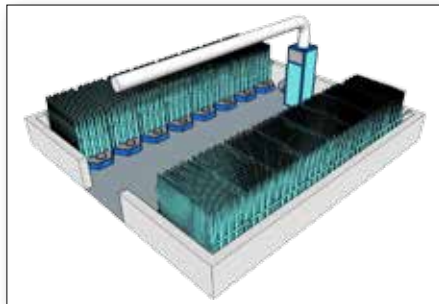

- For precise control of humidity and temperature in the drying room, especially with MAXI Trolley
- Optimal humidity and temperature control
- The machine will make sure the skins are dried correctly
- Built-in hygrostat and thermostat, humidity unit and heating unit
- Easy installation – all in one unit
- The machine only requires the connection of electrical power, water, a ventilation pipe and compressed air

Technical data	
Dimensions	W: 60 cm H: 183 cm D: 60 cm
Air quantity	16.060 m3/hour
KW peak	9,4
Electricity	3 x 400 Volt + N + PE
Waterworks water	Normal
Compressed air	Minimum 5 atm
Connection	CEE 32 A Plug + Air + Water

Price excl. installation EUR

10.795,00

Q-VEX CLIMA COMPACT HT FRIDGE

ITEM NO. 34100007



Q-VEX Clima Compact HT Fridge. Rebuilding with Fridge.

Price excl. installation EUR

1.960,00

HUMIDITY UNIT

ITEM NO. 34400002



Humidity unit for storage and drying room, with hygrostat. Very efficient, with 2 nozzles.

Price excl. installation EUR

2.560,00

JASOPELS STORAGE UNIT

ITEM NO. 34200003

Until 120 cubic meters, excl. installation, EUR

13.500,00

ITEM NO. 34200004

Until 240 cubic meters, excl. installation, EUR

17.560,00

The Jasopels Storage Unit is designed to be installed in the storage room. It maintains a temperature of between 10 and 12°C and a humidity of 75-80%.

The unit consists of a fan, a cooling unit, a humidity unit, sensors and an electronic control unit.

JASOPELS SOFT BRUSH

ITEM NO. 3140001



Price EUR
8.095,00

Cleans and brushes skins in a single procedure. The Soft Brush is easy and fast to use and makes the skin ready for delivery with optimal appearance. Wool and guard hair is given a lift, so the skins appear presentable and ready for evaluation.

- **Easy and fast to operate**
- **As an optional addition, a suction device that removes sawdust and dust from the skin can be installed**
- **Wool and guard hairs lifted**

Technical data

Electricity	3 x 400 Volt + N + PE, 1,5 kW
Air	50 l/min. and 8 bar
Connection	CEE 16
Dimensions	L: 250 cm H: 130 cm W: 90 cm

JASOPELS SKIN CLEANER T3

ITEM NO. 33230014



Price EUR
1.350,00

Thanks to using three brushes, one on the top side and two at the bottom, this machine does a very good job removing small pieces of loose dirt from the pelt and softening it.

Technical data

Electricity	3 x 400 Volt + PE
Air	1 l/min and 8 bar
Dimensions:	L: 55 cm H: 63 cm W: 28 cm
Connection	CEE 16 A plug



JASOPELS QUICK SOFTER 4M AUTOMATIC

ITEM NO. 3140003



Price EUR

2.015,00

- Automatic processing
- Moulded reels
- Extra strong piston
- Skins are blown through

The Quick Softer 4M is a machine with a great capacity. The machine softens the skin after drying. The skin is placed on the machine manually, after which the Quick Softer pulls the skin through a set of rolls that soften the skin on the leather side.

Technical data

Air	0-10 bar.
Dimensions	L.: 220 cm H.: 22 cm W.: 35 cm
Connection	Air



59100047
Valve 5/2 - MEV 25 ASS 00

JASOPELS LABEL MACHINE T2

ITEM NO. 3230033

The label Machine has a label magazine that can use all types of labels.

Technical data

Air consumption	0,75 l/min. - 8 bar.
Dimensions	L.: 41 cm. H.: 34 cm W.: 34 cm
Connection	Air



30400008
Senco Staples B05 / 8mm.



51600004
Tension spring 0,3x3x130

Price EUR
3.365,00

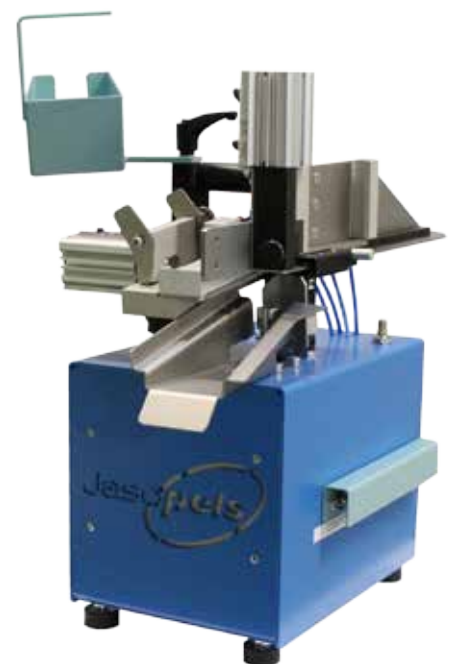



Item no.	Product description	Price
33300009	Screw compressor 7.5 kW Reno Monzun 10 HK 270 liter container & cooling dryer	*
33300010	Screw compressor 11 kW Reno Monzun 15 HK 270 liter container & cooling dryer	*
33300011	Screw Compressor 15 kW Reno Monzun 20 HK 500 liter container & cooling dryer	*
33300012	Compressor Reno 5.5 kW 7.5 HK 200 liter container	*
33300017	Compressor KGK 300-7522 Eff. air w/8 bar 680 liters	*
33300018	Screw Compressor 10 HK - 300 liter tank, with cooling dryer, eff. air 860 liters w/10 bars	*
33300019	Screw Compressor 15 HK - 300 liter tank, with cooling dryer, eff. air 1340 liters w/10 bars	*
33300020	Cooling dryer DRY18, up to 1800 liters/min	*

Please call for details and prices.



AVOID PROBLEMS WITH AIR AND WATER IN THE PELTING CENTER

There is no doubt about the importance of having enough air in the pelting center. It is unfortunate when operational errors occur during pelting due to pressure loss. Another stumbling block is when condensation gets into the valves and engine.

The lack of air usually triggers just a short break until the pressure is regained, whereas water in valves and engine can be more time consuming and more expensive!

If you are looking into switching your compressor, Jasopels recommends purchasing a screw compressor for numerous reasons.

They have a significantly higher performance rate, they are quieter compared to reciprocating compressors, and most importantly - they have an integrated cooling dryer that removes any condensation that forms naturally inside the tubing during temperature fluctuations.

If you have a newer conventional reciprocating compressor you do not want to replace, you should in any case seriously consider supplementing with a cooling dryer. It is an inexpensive insurance against operational interruptions and costly repairs.

SKIN TAGGING

Item no.	Product description	Price
30700010	1 Skin tagging gun, economic	26,35
30700011	2 Needle for skin tagging gun	6,45
30700012	3 Skin tags, 13 mm, for Mark II, 1000 pcs.	8,90

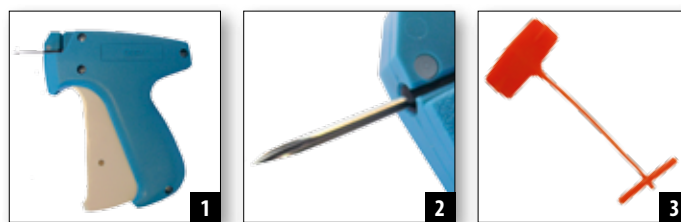

VACCINATION

Item no.	Product description	Price
30700002	1 Vaccination gun, Shooter 2 ml.	33,65
30700005	2 Cylinder and gasket for Shooter	10,20
30700006	3 Bottle holder for Shooter	17,20
30700003	4 Tube system and bottle holder	12,45
30700004	5 Quick lock (metal)	6,10
12600032	6 Nail scissors, model 7803	25,00



FLEA CONTROL

Item no.	Product description	Price
12100005	1 Permaforte, 10 l.	280,00
12100004	2 Bioinsect, 750 ml.	23,65
12100002	3 Loppex, 5 kg	120,75
12100003	4 Dimilin, 5 kg	207,00
12100011	5 Fly poison, Agita WG, 1 kg	189,90



FARM ARTICLES

Item no.	Product description	Price
12500016	1 Bags for disposal, clear	3,00
30700019	2 Stackable packaging box, white	28,70
12600034	3 Scales, without holder, 0-30 kg	580,00
12300068	4 Cage numbers with bar code, 50 pcs. per sheet	9,80
12300023	5 Breeding cards, male, 1 year	0,10
12300010	6 Breeding cards, female, 1 year	0,10
12300027	7 Cards for puppies	0,10
12300013	8 Breeding cards, 4 years	0,10
12600049	9 Feeding spoon	32,30



Item no.	Product description	Price
30500013	1 Knife, Gillette, regular	5,40
30500011	2 Knife blade, Paragon no. 23, small	0,40
30500005	3 Knife, Dick model 2259-6	20,70
30500006	4 Knife, Dick model 4070-4	13,40
30500020	5 Paw scissors SX 10	59,50
30500021	6 Cutting edge for scissors SX 10	26,80
30500022	7 Stopper for SX 10, nylon	3,95
30500014	8 Manual flesher with two handles	100,00
30500015	9 Knife f/tail flesher with counterweight, 5 pcs.	6,70
30500016	10 Rapid steel action	118,30
12600002	11 Moving trap, 5 x 5, with new locking fastenings	20,00
12600004	12 Catching trap, wire, 1 x 1	18,20
12600028	13 Catching net with steel frame	73,70
12600029	14 Catching tong/pliers, female	57,50
12600052	Farm rake, 16 teeth, width 60 cm	46,60
12600053	15 Farm rake, Galax, 15 teeth, adjustable	46,60
30500024	16 Plastic bag, clear, 60 x 120 super strong	0,75
33900025	17 Bucket holder with 3 wheels	270,00
12500013	18 Parvocide disinfectant 5 l.	88,00
12500018	19 Kickstart disinfectant 10 l.	145,00
12500020	20 Disinfection mat Soft 60 x 90 cm	63,00
12500021	Disinfection mat Soft 90 x 90 cm	93,00



GLOVES

Item no.	Product description	Price
12400010	1 Glove, no. 178, right	33,65
12400011	Glove, no. 178, left	33,65
12400012	2 Glove, no. 178, right, women's	33,65
12400013	Glove, no. 178, left, women's	33,65
12400002	3 Glove, no. 183, right	24,18
12400003	Glove, no. 183, left	24,18
12400004	4 Glove, no. 185, right	50,80
12400005	Glove, no. 185, left	50,80
12400018	5 Glove, no. 562, right	23,65
12400019	Glove, no. 562, left	23,65
12400022	6 Glove, no. 563, right	31,75
12400023	Glove, no. 563, left	31,75
12400029	7 Welding glove, 5 fingers, no. 663	8,24
12400033	8 Working glove, Europa	10,67
12400037	9 Working glove, Classic artic	16,90
12500001	10 Ninja HPT glove CE-11	3,40
12400051	11 Disposable shoes, 25 pairs	14,60



Page	Product description	Item no.	Dimensions	Weight	Electricity
22	Jasopels Feeding Machine 700	40100004	L: 255 cm. H: 150 cm. W: 87 cm.	462 kg.	
24	Jasopels Feeding Machine 950	40100007	L: 325 cm. H: 150 cm. W: 92 cm.	722 kg.	
25	Jasopels Feeding Machine 1500 - 1320 l.	40100010	L: 380 cm. H: 155 cm. W: 92 cm.	807 kg.	
25	Jasopels Feeding Machine 1500 - 1520 l.	40100012	L: 380 cm. H: 169 cm. W: 92 cm.	858 kg.	
26	Jasopels Feeding Machine 2000	40100013	L: 435 cm. H: 169 cm. W: 92 cm.	1073 kg.	
29	Jasopels MultiUnit	12600037	L: 330 cm. H: 106 cm. W: 96 cm.	125 kg.	
29	Jasopels BlueMotion	12600091	L: 150 cm. H: 130 cm. W: 75 cm.	200 kg.	24 Volt / 12 V outlet
29	Jasopels BlueMotion Trailer	12600092	L: 332 cm. H: 100 cm. W: 61 cm.	80 kg.	
30	Jasopels Grading Table	12600046	L: 152 cm. H: 164 cm. W: 595 cm.	150 kg.	1 x 230 Volt + N + PE
31	Jasopels Length Measuring Device	32300032	L: 100 cm. H: 130 cm. W: 360 cm.	55 kg.	Battery powered
34	Jasopels Trolley for bodies with 9 tiltable shelves	32500003	L: 215 cm. H: 194 cm. W: 95 cm.	222 kg.	
34	Jasopels Trolley for bodies with 8 tiltable shelves	32500004	L: 215 cm. H: 194 cm. W: 95 cm.	202 kg.	
36	Jasopels Body Drum XL	32400013	L: 400 cm. H: 200 cm. W: 180 cm.	1167 kg.	3 x 400 Volt + N + PE
36	Control Unit for Body Drum XL		L: 65 cm. H: 129 cm. W: 56 cm.	85 kg.	
37	Jasopels Body Drum	32400012	L: 240 cm. H: 210 cm. W: 175 cm.	748 kg.	3 x 400 Volt + N + PE
37	Jasopels Body Drum with sliding door, right	32400002	L: 230 cm. H: 182 cm. W: 124 cm.	400 kg.	3 x 400 Volt + N + PE
37	Jasopels Body Drum with sliding door, left	32400003	L: 230 cm. H: 182 cm. W: 124 cm.	400 kg.	3 x 400 Volt + N + PE
39	Jasopels Sawdust Heater	32500058	L: 215 cm. H: 190 cm. W: 75 cm.	355 kg.	3 x 400 Volt + N + PE,
39	Jasopels Skin Drum	32400011	L: 370 cm. H: 180 cm. W: 170 cm.	670 kg.	3 x 400 Volt + N + PE
40	Jasopels Skin Drum with sliding door, right	32400009	L: 272 cm. H: 199 cm. W: 126 cm.	516 kg.	3 x 400 Volt + N + PE
40	Jasopels Skin Drum with sliding door, left	32400010	L: 272 cm. H: 199 cm. W: 126 cm.	516 kg.	3 x 400 Volt + N + PE
40	Suction Device for Jasopels Body and Skin Drum	32200025	L: 135 cm. H: 250 cm. W: 66 cm.	95 kg.	3 x 400 Volt + PE
42	Jasopels Paw Cutter	32100040	L: 767 cm. H: 1332 cm. W: 842 cm.	180 kg.	3 x 400 Volt + N + PE
44	Jasopels Slicing Machine T3 XL	32100003	L: 120 cm. H: 120 cm. W: 65 cm.	100 kg.	1 x 230 Volt + N + PE
44	Jasopels Slicing Machine T4 XL	32100006	L: 120 cm. H: 120 cm. W: 65 cm.	100 kg.	1 x 230 Volt + N + PE
47	Skinnering Table with stainless table top	32100039	L: 110 cm. H: 113 cm. W: 125 cm.	110 kg.	
47	Extra plate for Skinnering Table		L: 117 cm. H: 92 cm. W: 45 cm.	42 kg.	
48	Jasopels MaxiHook T5, right	32100009	L: 130 cm. H: 66 cm. W: 50 cm.	95 kg.	1 x 230 Volt + N + PE
48	Jasopels MaxiHook T5, left	32100010	L: 130 cm. H: 66 cm. W: 50 cm.	95 kg.	1 x 230 Volt + N + PE
49	Jasopels Skinnering Machine T4 XL	32100011	L: 130 cm. H: 150 cm. W: 80 cm.	203 kg.	3 x 400 Volt + PE
49	Jasopels Skinnering Machine T11	32100035	L: 240 cm. H: 175 cm. W: 80 cm.	400 kg.	3 x 400 Volt + N + PE
51	Jasopels Skinnering Tower Automatic XL	32100041	L: 130cm. H: 247 cm. W: 80 cm.	230 kg.	3 x 400 Volt + N + PE
51	Jasopels Skinnering Tower	32100013	L: 120 cm. H: 220 cm. W: 80 cm.	162 kg.	3 x 400 Volt + N + PE
54	Jasopels Pelting Robot XXL	31200004	L: 380 cm. H: 128 cm. W: 200 cm.	850 kg.	3 x 400 Volt + N + PE
57	Jasopels Fleshing Machine T6	32200006	L: 500 cm. H: 200 cm. W: 115 cm.	1410 kg.	3 x 400 Volt + N + PE
57	Control til Jasoepels Fleshing Machine T6		L: 60 cm. H: 190 cm. W: 40 cm.		
60	Jasopels Fleshing Machine T4 XL	32200004	L: 440 cm. H: 190 cm. W: 100 cm.	1010 kg.	3 x 400 Volt + N + PE
61	Jasopels Rotating Fleshing Machine 4000 XXL	33100003	L: 238 cm. H: 184 cm. W: 125 cm.	405 kg.	3 x 400 Volt + N + PE
62	Jasopels Fat Pump	32200024	L: 150 cm. H: 200 cm. W: 90 cm.	205 kg.	3 x 400 Volt + N + PE
62	Jasopels Leather Side Drum	32200036	L: 240 cm. H: 130 cm. W: 110 cm.	223 kg.	3 x 400 Volt + PE
67	Jasopels Skin Washer	32300025	L: 91,5 cm. H: 141 cm. W: 113,5 cm.		1 x 220-240 Volt 3 AC
71	Jasopels Wrap Machine T5 Maxi Stretch	32300004	L: 80 cm. H: 125 cm. W: 80 cm.	185 kg.	1 x 230 Volt + N + PE
73	Jasopels Maxi Trolley	34500004	L: 195 cm. H: 100 cm. W: 85 cm.	112 kg.	1 x 230 Volt + N + PE
77	Jasopels Skin Cleaning Automat T5	32500001	L: 200 cm. H: 160 cm. W: 90 cm.	458 kg.	3 x 400 Volt + N + PE
79	Jasopels Q-Vex Clima	34100002	L: 60 cm. H: 183 cm. W: 60 cm.	125 kg.	3 x 400 Volt + N + PE
79	Q-veX Clima Compact HT Fridge	34100007	L: 60 cm. H: 110 cm. W: 50 cm.	66 kg.	1 x 230 Volt + N + PE
79	Humidity Unit	34400002	L: 21 cm. H: 40 cm. W: 30 cm.	15 kg.	1 x 230 Volt + N + PE
80	Jasopels Soft Brush	31400001	L: 250 cm. H: 130 cm. W: 90 cm.	202 kg.	3 x 400 Volt + N + PE
80	Jasopels Skin Cleaner T3	32300014	L: 55 cm. H: 63 cm. W: 28 cm.	36 kg.	3 x 400 Volt + PE
81	Jasopels Quick Softer 4M Automatic	31400003	L: 220 cm. H: 22 cm. W: 35 cm.	16 kg.	
81	Jasopels Label Machine T2	32300033	L: 41 cm. H: 34 cm. W: 34 cm.	15 kg.	

MACHINE OVERVIEW AND PRODUCT SPECIFICATION

KW peak max Air

Connection

6 Kw		CEE 16A plug
3 Kw		CEE 16A plug
1,5 Kw	0,05l./min. and 8 bar.	CEE 16A plug + Air
1,5 Kw	0,05l./min. and 8 bar.	CEE 16A plug + Air
3,75 Kw		CEE 16A plug
3 Kw		CEE 16A plug
1,5 Kw	2 l./min. max 8 bar.	CEE 16A plug + Air
1,5 Kw	2 l./min. max 8 bar.	CEE 16A plug + Air
2,2 Kw		CEE 16A plug "can be provided from the drum"
0,3 Kw	60 l./min. and 8 bar.	CEE 16A plug + Air
0,3 Kw	600 l./min. and 8 bar	230V plug + Air
0,3 Kw	600 l./min. and 8 bar	230V plug + Air
1,1 Kw	2 l./cykle, max 8 bar.	230V plug - AC/DC relay + Air
1,1 Kw	2 l./cykle, max 8 bar.	230V plug - AC/DC relay + Air
1,5 Kw	2,0 l./min. and 8 bar.	CEE 16A plug + Air
2,78 Kw	2,0 l./min. and 8 bar.	CEE 16A plug + Air
2,2 Kw	0,77 l./min. and 8 bar.	CEE 16A plug - AC/DC relay
2,2 Kw	0,77 l./min. and 8 bar.	CEE 16A plug - AC/DC relay
3,75 Kw	600 l./min. + min. 8 bar	CEE 16A plug - AC/DC relay + Air
15,88 Kw	10 l./min. and 8 bar.	CEE 32A plug - AC/DC relay + Air + Water
13,68 Kw	10 l./min. and 8 bar.	CEE 32A plug + Air
2,24 Kw	5 l./min. and 8 bar.	CEE 16A plug + Air
7,7 Kw		CEE 16A plug + 4x1,5 og 7x1,5 for start signal from Fleshing Machine
0,55 Kw		CEE 16A plug
1,8 Kw		
1,5 Kw	40 l./min. and min. 8 bar	230V stik - AC/DC relay + Air
0,25 Kw		CEE 16A 2 pole plug blue
6,4 Kw	268 l./min. and 8 bar.	CEE 16A plug + Air
9,4 Kw	Airflow 16.060 m3/time Heating element 9 kW. Compressed air 5 atm.	CEE 32A plug + Air + Water
2,2 Kw		230 V plug
0,3 Kw		In terminal + Luft + Water
0,92 Kw	50 l./min. and max 8 bar.	CEE 16A plug + Air
0,37 Kw	1 l./min. and 8 bar.	CEE 16A plug
	0-10 bar.	Air
	0,75 l./min. - 8 bar.	Air

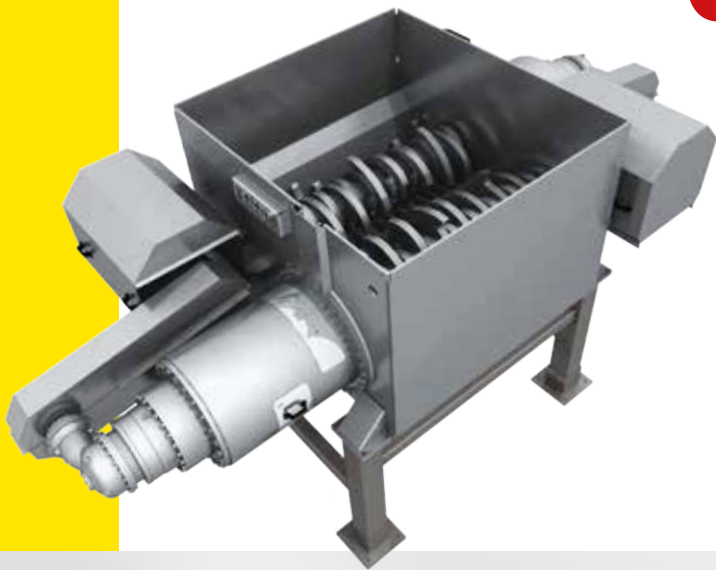

Twin Shaft Breaker P-4260

The Titan series Twin Shaft Breaker is the right choice for those who need maximum performance for processing frozen material. It crushes pallets up to 1000 mm x 1000 x 1500 mm. The perfect machine for a big producer.

Advantages:

- Crushes complete pallets
- Large feed inlet
- Large capacity

Technical data	
Effect	75-90 kW x 2
Length	2590 mm
Width	5840 mm
Height	1520 mm + 1200
Feed inlet	2000 x 2200 mm
Weight	14000 kg
Capacity	30-50 ton/h



Twin Shredder P-2400/450

The Titan series Twin Shredder is the ideal combination machine for processing both frozen and fresh raw material. It crushes and grinds the material in one step. The perfect machine for a medium sized feed kitchen.

Advantages:

- One machine does all the work
- low build-in dimension
- Less washing
- Good economy

Technical data	
Effect	75-90 kW x 2
Length	3015 mm
Width	3000 mm
Height	1000 mm
Feed inlet	1960 x 1460 mm
Weight	6500 kg
Capacity	10-20 ton/h



TERMS AND CONDITIONS

The following General sales and delivery terms shall apply to all deliveries from Jasopels A/S (Jasopels) unless otherwise expressly agreed.

1. Drawings, tools, etc.

- 1.1. All drawings and other technical documents which Jasopels may choose to deliver to the Customer shall remain Jasopels' property and shall not be copied, reproduced or otherwise wrongfully used.

2. Designs

- 2.1. Jasopels reserves the right, without prior notification, to make design changes which do not affect the specified function. With respect to products made to the Customer's specifications, the Customer shall guarantee that the products do not infringe third party's intellectual property rights.

3. Foreign goods

- 3.1. Goods which are handed over to Jasopels for processing or any other materials handed over to Jasopels and which belong to the Customer shall be stored at the Customer's expense and risk. Jasopels thus disclaims any liability for loss or damage, and it shall be the Customer's own responsibility to take out insurance.

4. Delivery of mink barns

- 4.1. The Customer shall take out and maintain a contractor's all risks insurance until defects identified on handing-over have been remedied. Jasopels shall be included as insured.
- 4.2. The Customer shall set out the defining main lines and heights (levels), but all other setting out shall be done by Jasopels.
- 4.3. The Customer shall obtain and pay for all required permits for the construction work.
- 4.4. The Customer shall carry the risk for obstructions resulting from subsoil water and soil conditions, contamination etc.
- 4.5. Service pipes and lines for drainage, electricity etc. shall be installed on the construction site by the customer.

5. Offers and acceptance

- 5.1. Unless otherwise specified, offers from Jasopels shall be valid for fourteen (14) days from the date of the offer.
- 5.2. The Customer's acceptance in writing shall be without reservations with respect to the terms specified in the offer and it shall be received by Jasopels before the deadline for acceptance. In the event that the acceptance is inconsistent with the offer, the acceptance shall be deemed to be a new offer. Jasopels shall not be bound by the content of the acceptance unless Jasopels has accepted the new offer in writing and it is evident from the circumstances that Jasopels was aware of the inconsistency.

6. Price

- 6.1. Prices quoted are based on current prices and costs, including material prices, wages and other manufacturing costs, on the date of the offer/order confirmation. Changes in the above prices and costs prior to delivery, including changed or new taxes or duties, shall entitle Jasopels to adjust the offered/confirmed prices accordingly.

7. Delivery

- 7.1. Delivery of goods from Jasopels shall be according to INCOTERMS 2010 EX WORKS Jasopels' address in Bording, Denmark, unless otherwise agreed.
- 7.2. Should Jasopels choose to effect delivery of the goods to the Customer, Jasopels shall be acting as the Customer's agent at the Customer's expense and risk. In such cases, the right to dispose of the goods in transport law shall remain with Jasopels, which will also be entitled to effect delivery freight collect. Delivery in such cases will normally be by road.
- 7.3. The delivery date shall be calculated from the date on which Jasopels receives full information concerning the execution of the order, including all requisite technical details and formalities.
- 7.4. All delivery dates are approximate. A delay can only be deemed to be material after minimum thirty (30) days from the agreed delivery date.

8. Payment

- 8.1. Payment shall be made net cash. In the event of late payment, interest of two (2) per cent per month or part of a month shall be incurred. In the event of default by the Customer on the terms of payment, Jasopels shall be entitled to suspend fulfilment of all remaining orders from the Customer. If the arrears are not paid by a further short deadline fixed by Jasopels, Jasopels shall be entitled to cancel all agreements concluded with the Customer.

9. Retention of title

- 9.1. Jasopels shall retain title in the goods sold until payment is made.

10. Force majeure etc.

- 10.1. In the event of force majeure, including strikes and stoppages, lockouts, fire, flooding, major breakdowns, extensive interruptions to operations, acts of war, import and export bans, seizure, government measures, obstruction by ice, wreck or loss of ship, transport delays, non-delivery or defective delivery from subcontractors, raw material or energy shortages or any other events over which Jasopels has no control, Jasopels shall be entitled to postpone or cancel execution of an order. The Customer shall not be entitled to claim damages or make any other claims against Jasopels in the event of such postponement or cancellation.

11. Complaints and period of limitation

- 11.1. The Customer shall examine the delivered goods immediately upon receipt.
- 11.2. Complaints shall be made in writing and for visible defects and defects which ought to have been discovered when the Customer examined the goods, cf. point 11.1, no later than eight (8) days from the latter of the invoice date and the date of delivery. In other cases, complaints shall be made no later than eight (8) days after the Customer became aware of the circumstance occasioning the complaint. The complaint will otherwise not be considered.
- 11.3. Jasopels' liability for defects, cf. point 12.2 below, shall lapse if Jasopels has not received a complaint from the Customer within one (1) year of delivery of the goods.

12. Liability

- 12.1. In the event of delays attributable to Jasopels, Jasopels shall be liable for the Customer's documented losses due to the delays in accordance with the general rules of Danish law. However, no compensation shall be granted to the Customer for any operating loss, loss of profit or other indirect loss, including loss as a result of the Customer's legal relationship with third parties, and the compensation shall be limited to and shall not exceed the agreed purchase price for the delayed goods.
- 12.2. In the event of defects in the delivery which may be claimed against Jasopels, Jasopels shall be entitled, at its discretion, to remedy the defect or make a replacement delivery as long as this is done within thirty (30) days of the Customer's timely complaint submitted in writing to Jasopels in such a way that it is possible for Jasopels to decide whether to remedy the defect or make a replacement delivery. In the event that the delivery has been carried outside Denmark by the Customer, the Customer shall either transport the delivery to Denmark at its own expense or pay all Jasopels' extra costs of remedying the defect outside Denmark. In the event that Jasopels remedies the defect or makes a replacement delivery, the Customer shall not be entitled to make any other claims against Jasopels as a result of the discovered defects. In the event that Jasopels does not remedy the defect or make a replacement delivery, Jasopels shall pay compensation under the general rules of Danish law. However, no compensation shall be granted to the Customer for any operating loss, loss of profit or other indirect loss, including loss as a result of the Customer's legal relationship with third parties, and the compensation shall be limited to an amount equalling the costs of remedying the defect in the delivery and shall not exceed the agreed purchase price.
- 12.3. Jasopels assumes no liability for product liability which does not follow from the mandatory rules of the Danish Product Liability Act. In particular, Jasopels shall not be liable for operating loss or any other indirect loss. To the extent to which Jasopels incurs product liability to a third party, the Customer shall indemnify Jasopels to the same extent to which Jasopels has limited its liability as above. The Customer shall agree to be sued in the court which hears the product liability case against Jasopels.

13. Venue and choice of law

- 13.1. The agreed venue for any disputes between the parties shall be Herring Court, Haraldsgade 28, 7400 Herning, Denmark. Jasopels shall, however, be entitled, alternatively and at its discretion, to bring a case before the court at the location of the Customer's business premises as an alternative.
- 13.2. Any dispute between the parties shall be settled in accordance with Danish law, apart from the Danish international applicable law rules.

March 2016

 **Springbrook
Fur Farm Limited**
1561 Berlett's Road,
St. Agatha, Ontario, N0B 2L0,
Canada
Phone: + 1 519 885 0970
Fax: + 1 519 885 2373
E-mail: springbrk@golden.net

 **Ipves**
Nijkerkerstraat 51
3882 LD Putten, Holland
Phone: + 31 341 769 094
Mob: + 31 06 11406122
Email: info@ipves.nl

 **MINKOMAT AB**
Gottåkravägen 14B
23641 Höllviken, Sweden
Phone: + 46 404 50320
Mob: + 46 706 004 800
E-mail: minkomat@telia.com

 **Mon ehf**
Ásaskóli 801 Selfoss, Iceland
Phone: + 354 865 8776
E-mail: kast@pax.is

 **Ert Eelmets**
Ertel.ee OÜ
Väana 7-18
11612 Tallinn, Estonia
Mob: +37 250 316 42
Fax: +37 253 071 537
E-mail: ert@ertel.ee,
info@ertel.ee
skype: ert.eelmets

 **Jasopels Sp. z o.o.**
Ul. Łukowska 12
64-600 Oborniki, Poland
Phone: + 48 61 855 2776
Fax: + 48 61 811 7610
E-mail: js@jasopels.pl

 **Savi di Pozza
Luciano**
Contra Pezzini, 2
36062 Conco VI, Italy
Phone: + 39 042 470 0379
Fax: + 39 042 470 0379
Mob: + 39 339 755 7356
E-mail: pozzaluciano@alice.it

 **Einar Johan Sirevag**
Havraskaret 17
4364 Sirevag, Norway
Phone: + 47 909 652 01
Fax: + 47 514 366 36
E-mail: ej-si@online.no

 **OY Petsmo Products AB**
Kruunantic 30
65230 Vaasa
Finland
Phone: +358 207908611
Fax: +358 63234655
E-mail: jens.osterberg@wel-mach.fi

 **UAB Zverininkystes
Iranga**
Zalioji str. 10
Kretingale, Kleipėdos r.
LT - 96044 Lithuania
Mob: +37 061 254 601
Fax: +37 046 446 757
E-mail: rrybakas@gmail.com,
iranga.parts@gmail.com

 **Nikolaos dim. Kafasis**
Thoma Tsipou str. 34
50300 Siatista, Kozani, Greece
Phone: +30 694 793 3813
Phone: +30 694 484 1599
E-mail: kafasis@hol.gr

 **Shanghai Petsmo
Trading Co., Ltd.**
Puxing Road, Fangxian District
Room 180
Sixth Building No. 8989
Shanghai, China
Att.: John Asmussen
Mob: (+45) 60 62 21 53
(+86) 1368 3646572

 **Visotenic, S.L.**
Pol. ind. "Área 33", zona 10, n.º 2
36540 Silleda (Pontevedra)
Spain
Phone: (+34) 661.423.635
(+34) 650 342 982
E-mail: visotenic@gmail.com

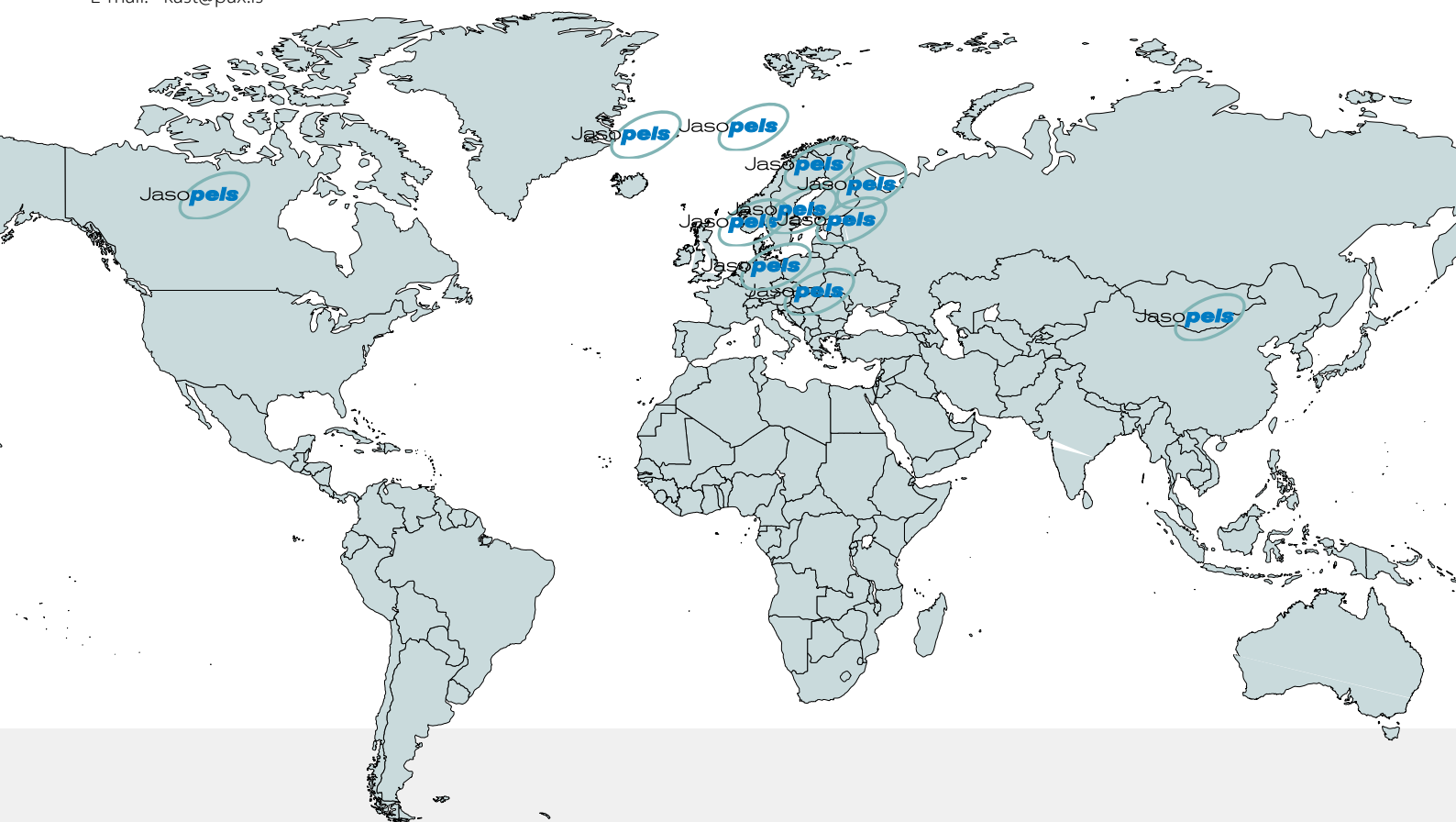

JASOPELS INTERNATIONAL ADDRESS

Fabriksvej 19 · DK-7441 Bording, Denmark
Phone: +45 89 20 61 88
Mobile: +45 509 161 333
Fax: +45 89 20 61 87
Webpage: www.jasopels.com

Monday - Thursday 8.00 - 16.00 CET
Friday 8.00 - 14.00 CET

Bank:
Danske Bank,
Prinsensgade 11,
DK-9000 Aalborg, Denmark
SWIFT: DABADKKK
IBAN: DK7030003201396719